

207 SERIES

Vertical Hold Down Clamps | Product Overview

Features:

- Largest selection of arm and mounting options
- Low profile T-Handle version available
- Available in stainless steel
- BLK models feature a black, non-reflective finish

Applications:

- Checking fixtures
- Assembly & test
- Light machining
- Woodworking

Also Available:

See page MC-ACC-1 for accessories

807-U Pneumatic toggle clamp
(See page MC-PTC-6)

807-S Pneumatic toggle clamp
(See page MC-PTC-6)

Accepts M8 or 5/16 spindle accessories

207-U
Flanged Base
U-Bar



-SS Stainless
Steel Model



207-UL
Flanged Base
Long U-Bar



207-S
Flanged Base
Solid Bar



207-L
Flanged Base
Long Solid Bar



207-TU
Flanged Base
T-Handle
U-Bar



207-TUL
Flanged Base
T-Handle
Long U-Bar



207-UR
Flanged Base
U-Bar
DESTACO®
Toggle Lock
Plus



207-LR
Flanged Base
Long Solid Bar
DESTACO®
Toggle Lock
Plus



207-UB
Straight Base
U-Bar



207-ULB
Straight Base
Long U-Bar



207-SB
Straight Base
Solid Bar



207-LB
Straight Base
Long Solid
Bar



207-LBR ⓘ
Straight Base
Long Solid Bar
DESTACO®
Toggle Lock
Plus



207-UF ⓘ
U-Bar
Dual Mount



207-SF ⓘ
Solid Bar
Dual Mount



207-U-L ⓘ
Flange Base
Open Bar



207-U-L-BLK
Blackout Series
Flanged Base
Open U-Bar



207-UB-L ⓘ
Straight Base
Open Bar



207-UB-L-BLK
Blackout Series
Straight Base
Open U-Bar



207305

Flanged Grip. Provides added safety and protection. Fits all 207 Series (except T-Handle) clamps. Order separately.



ⓘ This item is available upon request

207 SERIES

Vertical Hold Down Clamps | Technical Information

Model	Max. Holding Capacity	Clamp Bar Opening (+10°)	Handle Opening (+10°)	Weight	Accessories (Supplied)						
					Bolt Retainer	Spindle Assembly	Flanged Washers				
207-U	1670 N [375 lbf]	99°	57°	0,30kg [0.67lb]	---	225208-M	507107				
207-UR				0,45kg [1.00lb]							
207-UL				0,30kg [0.67lb]							
207-USS	2000 N [450 lbf]			---	207943-M	507907					
207-S	2220 N [500 lbf]			99°	57°	0,31 kg [0.69lb]	207105	---	---		
207-L						0,34kg [0.74lb]					
207-LR						0,45kg [1.00lb]					
207-UB	1670 N [375 lbf]					99°	57°	0,33kg [0.72lb]	---	225208-M	507107
207-ULB								0,31 kg [0.69lb]			
207-SB								0,34kg [0.75lb]			
207-LB	2220 N [500 lbf]	99°	57°					0,45kg [1.00lb]	207105	---	---
207-LBR ⓘ								0,33kg [0.72lb]			
207-TU								0,33kg [0.72lb]			
207-TUL	1670 N [375 lbf]							96°	56°	---	---
207-UF ⓘ				0,38kg [0.84lb]							
207-SF ⓘ				0,38kg [0.84lb]							
207-U-L ⓘ	1670 N [375 lbf]			99°	57°					---	---
207-U-L-BLK ⓘ						507107-BLK					
207-UB-L ⓘ						507107					
207-UB-L-BLK ⓘ						507107-BLK					

ⓘ This item is available upon request

Holding Capacities

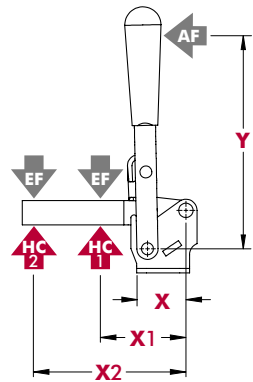

Model	X	X1	X2	Y	±HC1	±HC2	±EF(X1):AF	±EF(X2):AF	
U/UB/UR	[1.28] 32,6	[2.00] 50,8	[3.75] 95,3	[4.90] 124,5	[375 lbf] 1670N	[225 lbf] 1000N	12:1	6:1	
UL/ULB		[3.88] 98,5	[5.00] 127		[3.66] 9	[150 lbf] 670N	[150 lbf] 670N	7:1	4:1
USS		[2.00] 50,8	[3.75] 95,3			[450 lbf] 2000N	[240 lbf] 1070N	10:1	7:1
S/SB		[2.88] 73,0	[5.00] 127	[375 lbf] 1670N	[350 lbf] 1560N				
L/LR LB/LBR		[2.88] 73,0	[5.00] 127	[3.66] 9	[375 lbf] 1670N	[225 lbf] 1000N	6:1	4:1	
TU		[2.00] 50,8	[3.75] 95,3	9	[375 lbf] 1670N	[150 lbf] 670N	4:1	3:1	
TUL		[2.00] 50,8	[3.75] 95,3	[4.90] 124,5	[375 lbf] 1670N	[225 lbf] 1000N	12:1	6:1	
U-L		[2.00] 50,8	[3.75] 95,3	[4.90] 124,5	[375 lbf] 1670N	[225 lbf] 1000N	12:1	6:1	
UB-L		[2.00] 50,8	[3.75] 95,3	[4.90] 124,5	[375 lbf] 1670N	[225 lbf] 1000N	12:1	6:1	

Dimensions shown "mm [inch]" ± HC = Holding Capacity, EF = Exerting Force, AF = Applied Force

207 SERIES

Vertical Hold Down Clamps | Dimensions | -U/-UL/-S/-L/-TU/-TUL/-UR/-LR/-UB/-ULB/-SB/-LB/-LBR

207-U
Flanged Base
U-Bar

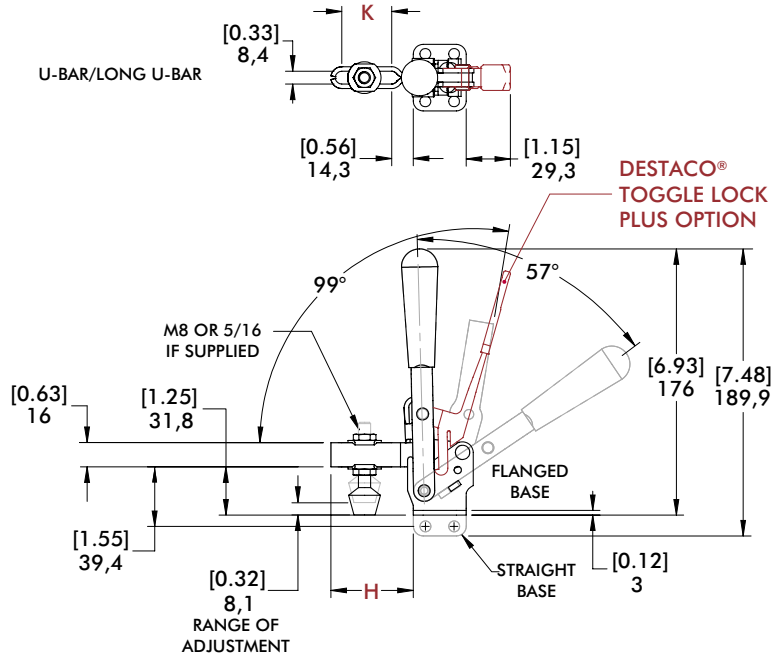
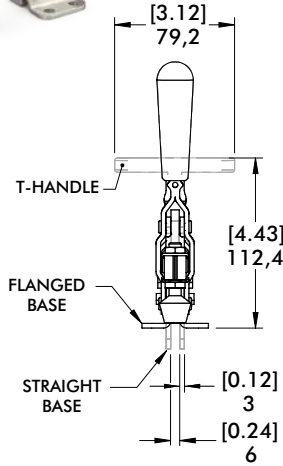

207-SB
Straight Base
Solid Bar

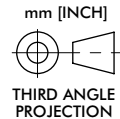
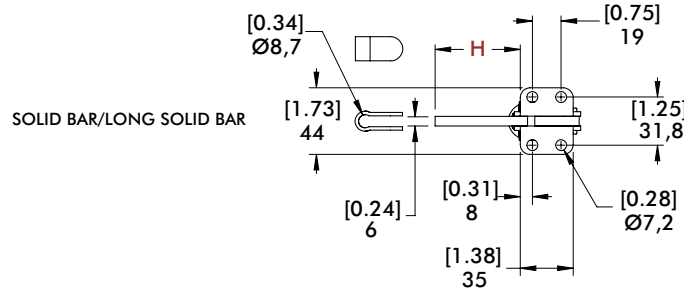

Bar Style	Clamp Models	H	K
	207-U/207-UR/207-TU/207-UB	[2.14] 54,4	[1.30] 33
	207-UL/207-ULB/207-TUL	[3.84] 97,6	[2.94] 74,6
	207-S/207-SB	[2.21] 56,2	---
	207-L/207-LR/207-LB/207-LBR ⓘ	[3.48] 88,4	---

ⓘ This item is available upon request

