



Rotary table cylinder—HRS Series

Compendium of HRS Series

Double cylinder structure

Reinforced cylinder structure allows for double output to be achieved.

Rack and pinion design

Rack and pinion design, provides stable operation.

With magnetic switch slots

Switch slots are designed on the both side of the cylinder body.

Five specifications are available

Specification: 10、15、20、30、40

Two modes of buffer could be chosen

Bumpers and air cushion provided as standard options, providing excellent cushion performance.

Simple to install

With guide holes on both sides of the cylinder body, installation is simple.

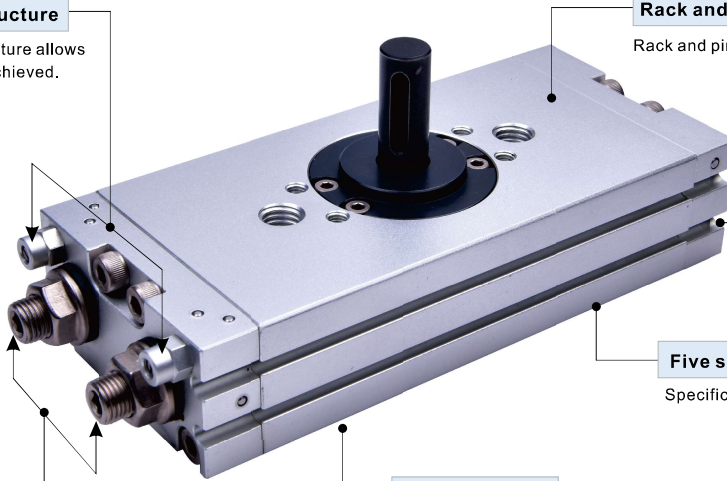

Installation and application



1. Dirty substances in the pipe must be eliminated before cylinder is connected with pipeline to prevent the entrance of impurities into the cylinder.
2. The medium used by cylinder requires 40 micron or lower filtration.
3. Anti-freezing measure shall be adopted under low temperature environment to prevent moisture freezing.
4. If unit or components to be stored for an extended period of time, it is recommended to apply an anti corrosive treatment to exterior. Dust caps shall be added in air inlet and outlet ports.



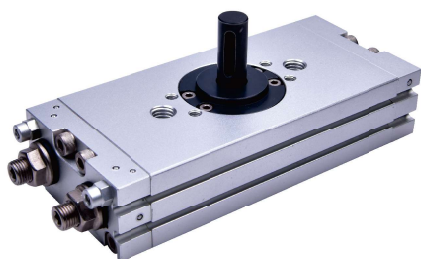

Symbol

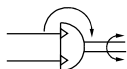

Product feature

1. Rack and pinion design, stable functioning.
2. Double cylinder structure, double force could be achieved.
3. Guide hole is designed on the both side of the cylinder body, which is simple to install.
4. Standard come with both bumper and air cushion, providing excellent cushion performance.

Note : HRS10/15 only has bumpers (do not have air cushion).

Specification

Specification	10	15	20	30	40
Acting type	Double rack and pinion(Double acting)				
Fluid	Air(to be filtered by 40μm filter element)				
Operating pressure	0.25~0.7MPa (37~100psi)(2.5~7.0bar)		0.15~0.7MPa (22~100psi)(1.5~7.0bar)		
Proof pressure	1.2MPa(175psi)(12.0bar)				
Temperature	-20~70°C				
Angle adjustment range	0~190°				
Repeatable precision	0.2°				
Theoretic moment(N.m)(0.5MPa)	0.33	1.1	2.2	2.8	5
Cushion type	Rubber bumper		Bumper and air cushion		
Port size	M5×0.8		1/8" [Note1]		
Weight g	145	359	822	1120	1806

[Note1] G thread is available.

Add) Refer to P590 for detail of sensor switch.

Ordering code

HRS 20 X 90° G

① ② ③ ④

① Model	② Specification	③ Rotating angle	④ Thread type
HRS: Rotary Table/Rack & Pinion Style	10	90° 180°	No this code
	15		G: G
	20		
	30		
	40		

[Note] HRS series are all come with magnet.

Inner structure and material of major parts

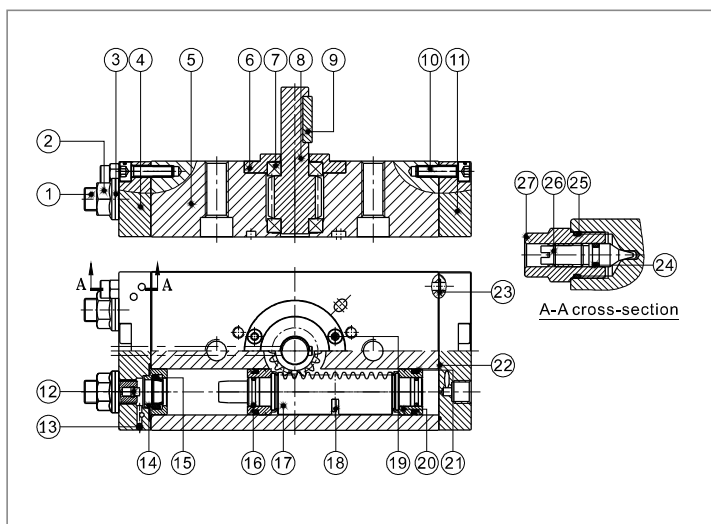

Note: inner structure & material data sheet is based on certain bore size. Please contact AirTAC if you need inner structure & material data sheet for specific bore size.

NO.	Item	Material
1	Adjustment bolt	Carbon steel
2	Hexagon nut	Carbon steel
3	Seal washer	Carbon steel & Rubber
4	Front cover	Aluminum alloy
5	Body	Aluminum alloy
6	Top cap	Carbon steel
7	Deep-groove bearing	Subassembly
8	Gear shaft	Carbon steel
9	Flat key	Carbon steel
10	Hexagon socket head cap bolt	Carbon steel
11	Back cover	Aluminum alloy
12	Bumper	NBR
13	Steel ball	Stainless steel
14	Buffering Cap	Aluminum alloy
15	O-ring	NBR
16	O-ring	NBR
17	Rack	Stainless steel
18	Magnet	Rare earths
19	Hexagon socket head cap bolt	Carbon steel
20	Piston	Brass
21	Piston seal	NBR
22	O-ring	NBR
23	O-ring	NBR
24	O-ring	NBR
25	O-ring	NBR
26	Air cushion screw	Brass
27	Screw	Brass/Carbon steel

Rotary table cylinder

HRS Series

Dimensions

HRS10/15

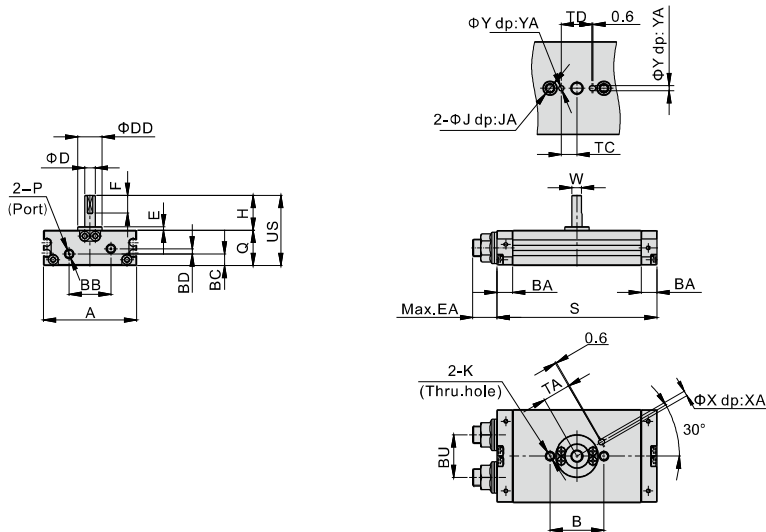

Type	Item	Rotating angle	A	EA	B	BA	BB	BC	BD	BU	D	DD	E	F	H	K	W	Q	S	US	TA	TC	TD	J	JA	X	XA	Y	YA	P
10		90°	42.5	11.4	29	8.5	16.7	5.5	6	16.7	5	12	2	10	18	M5×0.8	4.5	17	62	35	15.5	8	15.4	7.5	4.5	3 (H9)	2	3 (H9)	2	M5×0.8
		180°																	69											
15		90°	53.5	14	31	9	24.5	6.5	0	24.5	6	14	2	10	20	M5×0.8	5.5	20	75	40	16	9	17.6	7.5	4.5	3 (H9)	2	3 (H9)	2	M5×0.8
		180°																	92											

HRS20/30/40

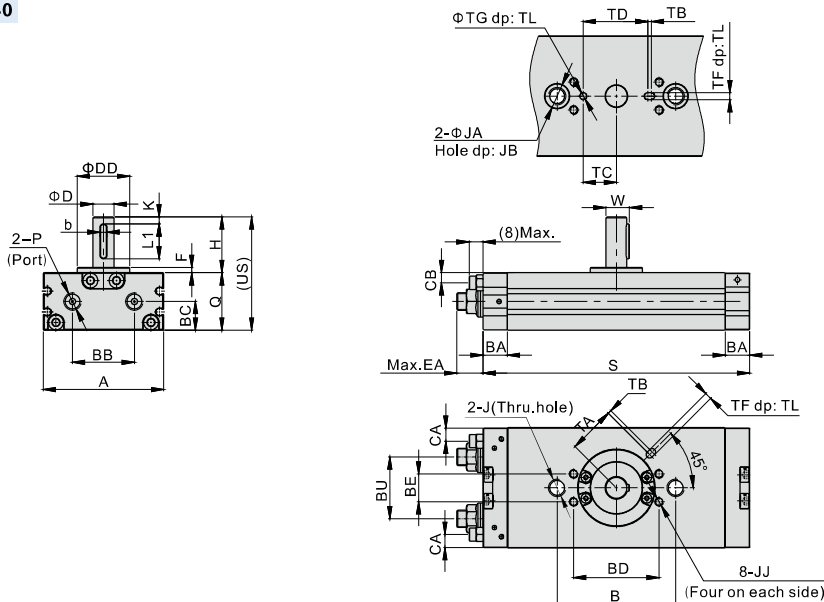

Type	Item	Rotating angle	A	B	EA	BA	BB	BC	BD	BE	BU	CA	CB	D	DD	F	H	J	JA
20		90° 180°	63	50	14.5	14	32.5	14.5	/	/	32.5	6	4.8	10	25	2.5	30	M8X1.25	11
30		90° 180°	69	68	14.5	14	35.5	16.5	49	16	35.5	7.5	5.8	12	30	3	32	M10X1.5	14
40		90° 180°	81	76	19.5	16	44	18.5	55	16	44	7	6.5	15	32	3	36	M10X1.5	14

Type	Item	Rotating angle	JB	K	JJ	P	Q	S	W	key		US	TA	TB	TC	TD	TF	TG	TL		
											b	L1									
20		90°	6.5	3	/	1/8"	29	110	11.5	4	20	59	24.5	1	13.5	27	4(H9)	4(H9)	2.5		
		136																			
30		90°	8.5	4	M5X0.8 dp:6	1/8"	33	122	13.5	4	20	65	27	2	19	37	4(H9)	4(H9)	2.5		
		153																			
40		90°	8.5	5	M6X1 dp:7	1/8"	37	141	17	5	25	73	32.5	2	20	39.5	5(H9)	5(H9)	3.5		
		179																			