

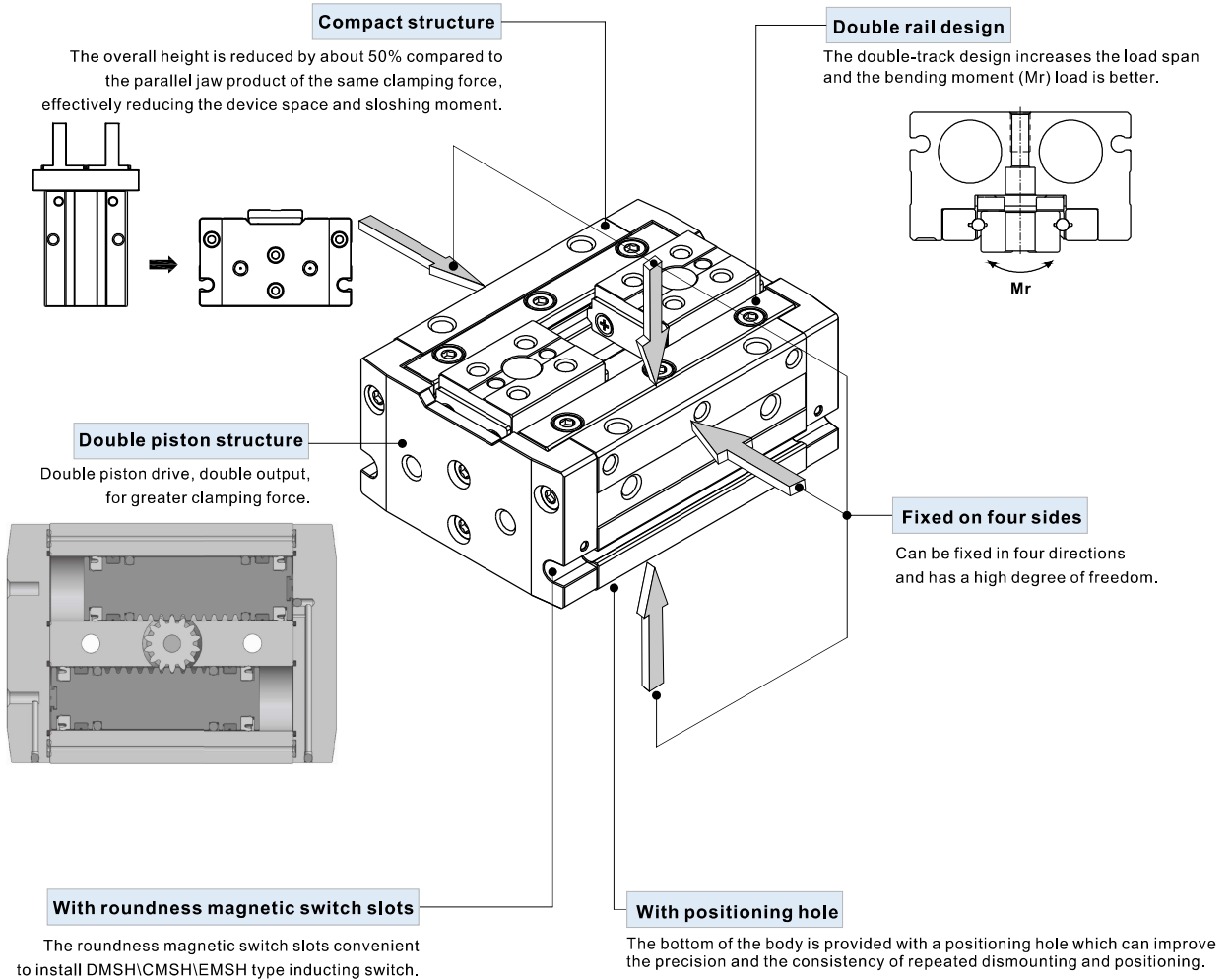

Compact air gripper—HFD Series

Compendium of HFD Series



Gripping force and stroke

Bore size	8			12			16			20			25	
Stroke (mm)	8	15	30	10	25	50	15	30	60	20	40	80	40	80
Gripping force per finger Effective value(N)	19			48			90			141			210	
Weight (g)	88.8	105.7	153.4	226.7	303.7	441.9	505.3	642.3	946.7	1019.6	1319.1	1983.3	1693.7	2558.9

[Note] The gripping force in the above table is in the working pressure of 0.5MPa, and with a gripping point of L=20mm.





Specification

Bore size (mm)	8	12	16	20	25
Acting type	Double acting				
Fluid	Air (to be filtered by 40µm filter element)				
Operating pressure	Φ8	0.25~0.7MPa(36~100psi)(2.5~7bar)			
	Φ12	0.2~0.7MPa(29~100psi)(2~7bar)			
	Φ16/20/25	0.15~0.7MPa(22~100psi)(1.5~7bar)			
Proof pressure	1.2MPa(175psi)(12bar)				
Temperature	-20~70°C				
Lubrication	Not required				
Repeatability mm	±0.05				
Max. frequency	Longer stroke: 60(c.p.m)				
	Middle and short stroke: 120(c.p.m)				
Sensor switches	CM5H, DMSH, EMSH				
Port size	M3×0.5		M5×0.8		

Note) Refer to P565 for detail of sensor switch.

Symbol

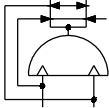

Ordering code

HFD 16 X 15

① Model	② Bore size	③ Stroke		
HFD: Compact air finger (Double acting)	8	8	15	30
	12	10	25	50
	16	15	30	60
	20	20	40	80
	25	40	80	

Product feature

1. The double-track design increases the load span and the bending moment (Mr) load is better.
2. Double piston drive, double output, for greater clamping force.
3. The bottom of the body is provided with a positioning hole which can improve the precision and the consistency of repeated dismounting and positioning.
4. The jaw rails are made of stainless steel for high rigidity and corrosion resistance.
5. Can be fixed in four directions and has a high degree of freedom.
6. The overall height is reduced by about 50% compared to the parallel jaw product of the same clamping force, effectively reducing the device space and sloshing moment.

Inner structure and material of major parts

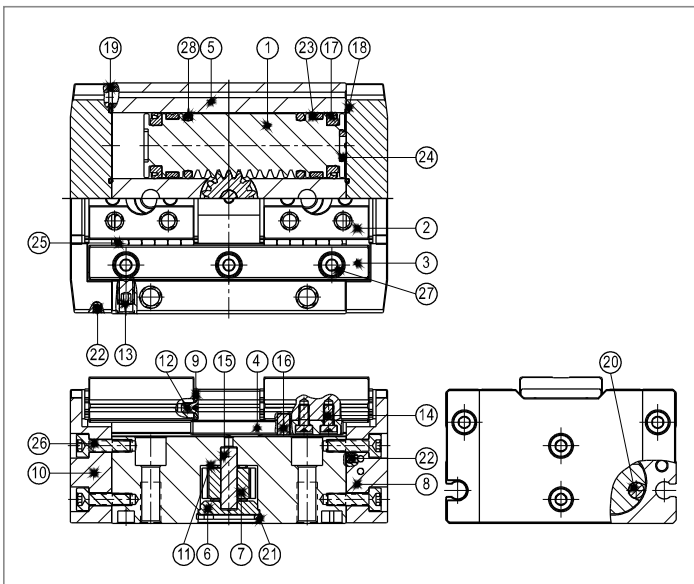

Note: inner structure & material data sheet is based on certain bore size.
Please contact AirTAC if you need inner structure & material data sheet for specific bore size.

NO.	Item	Material
1	Rack	Stainless steel
2	Jaws	Stainless steel
3	Guide	Stainless steel
4	Joint arm	Cr-Mo steel
5	Body	Aluminum alloy
6	Rack end cap	Aluminum alloy
7	Gear	Cr-Mo steel
8	Back cover	Aluminum alloy
9	Baffle	Stainless steel
10	Front cover	Aluminum alloy
11	Plastic bearing	Wear resistant material
12	Screw	Stainless steel/Alloy steel
13	Screw	Alloy steel
14	Screw	Alloy steel
15	Pin	Bearing steel
16	Pin	Bearing steel
17	Piston seal	NBR
18	O-ring	NBR
19	O-ring	NBR
20	Magnet	Rare earth material
21	C clip	Spring steel
22	Steel ball	Stainless steel
23	Wear ring	Wear resistant material
24	Bumper	TPU
25	Steel ball	Bearing steel
26	Bolt	Alloy steel/Stainless steel
27	Bolt	Alloy steel/Stainless steel
28	O-ring	NBR

Note: HFD8 No. 12 and No. 27 are made of alloy steel.

Compact air gripper

HFD Series

Dimensions

HFD8X8

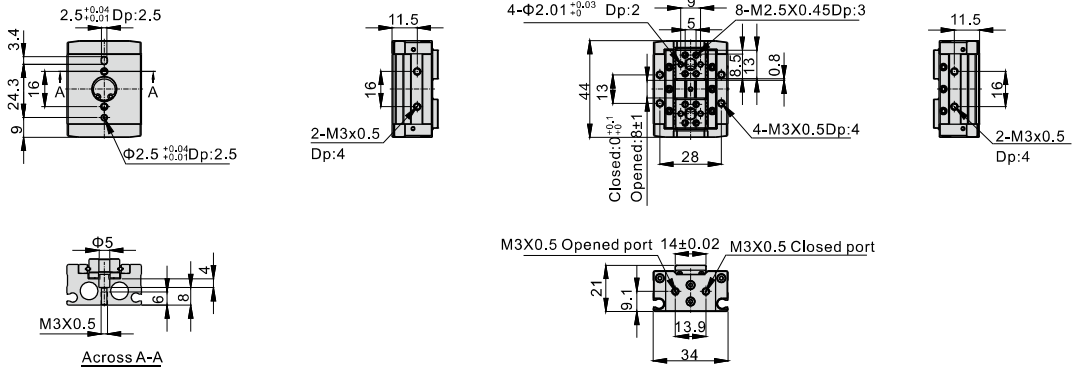

HFD8X15

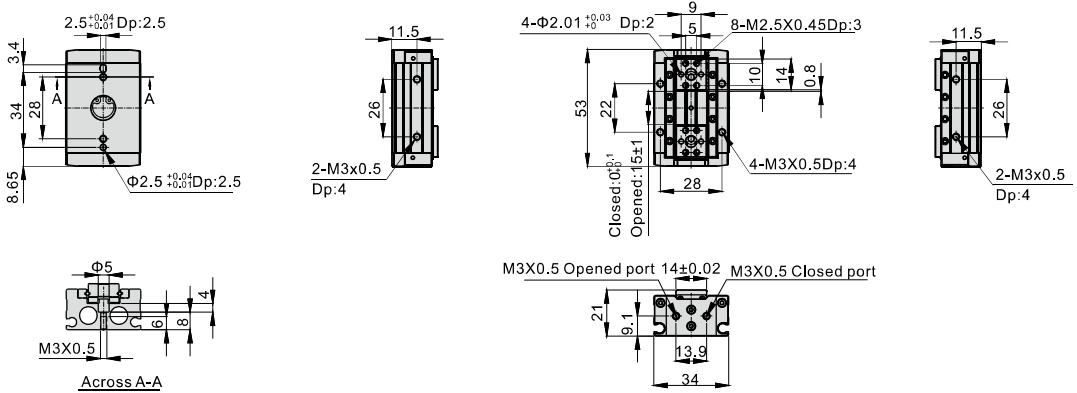

HFD8X30

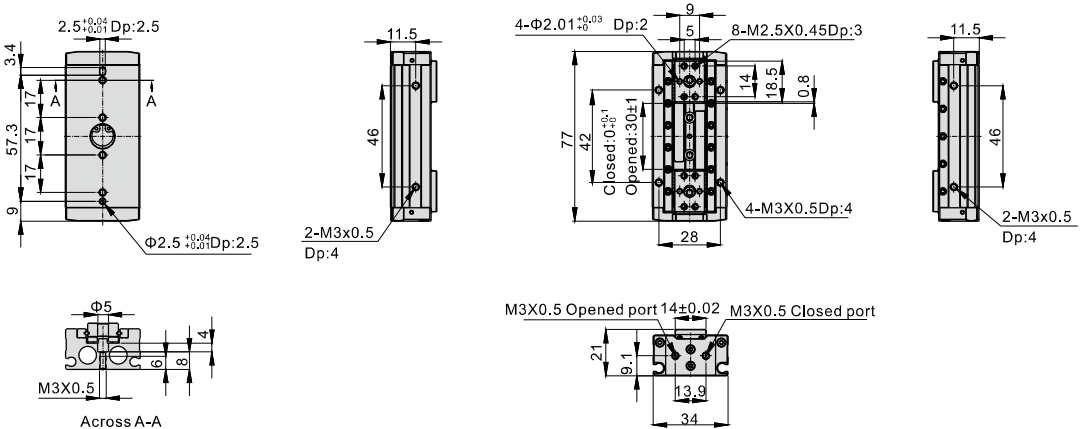

Compact air gripper

HFD Series

HFD12X10

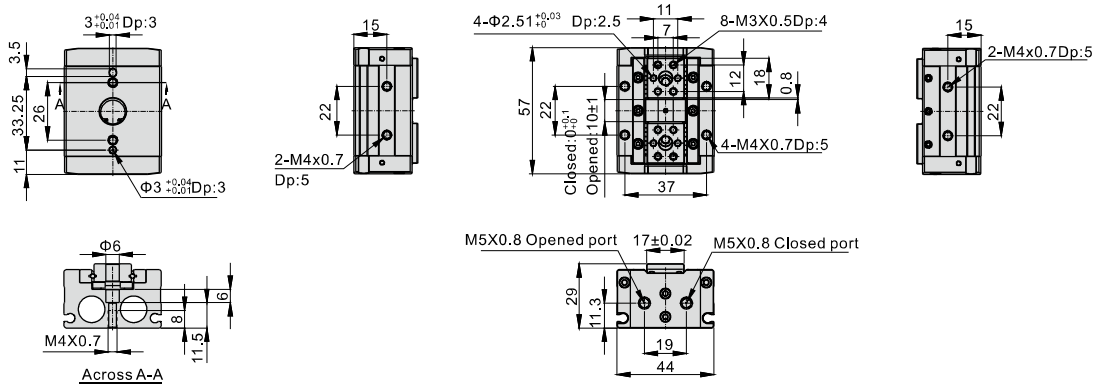

HFD12X25

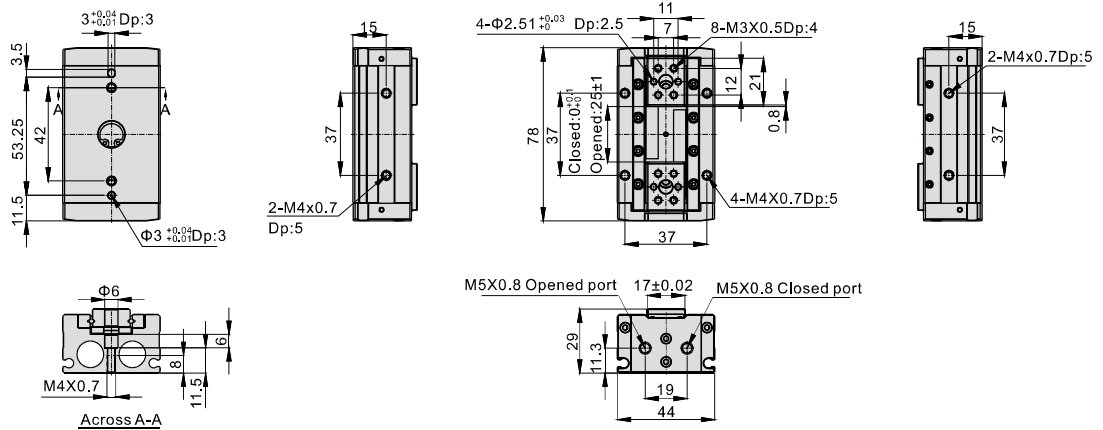

HFD12X50

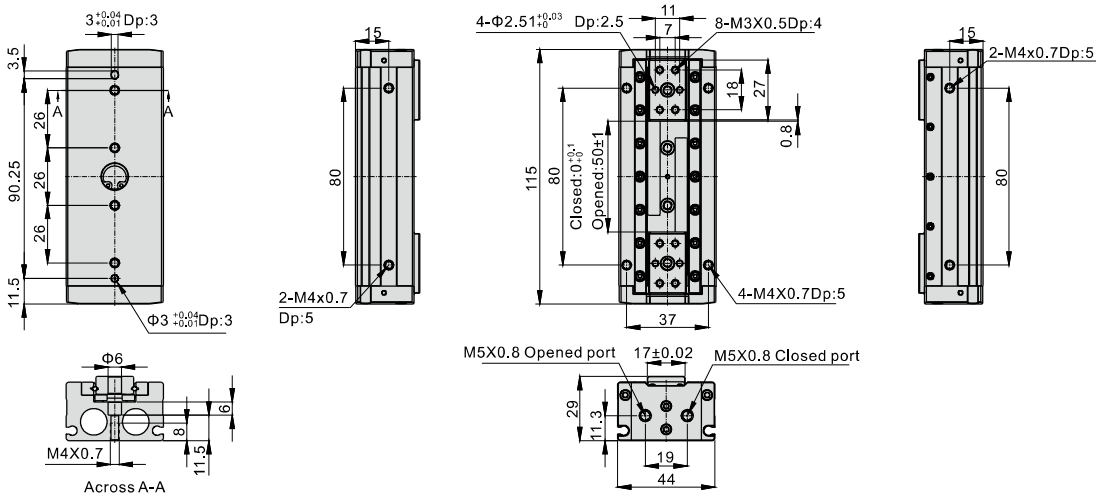

Compact air gripper

HFD Series

HFD16X15

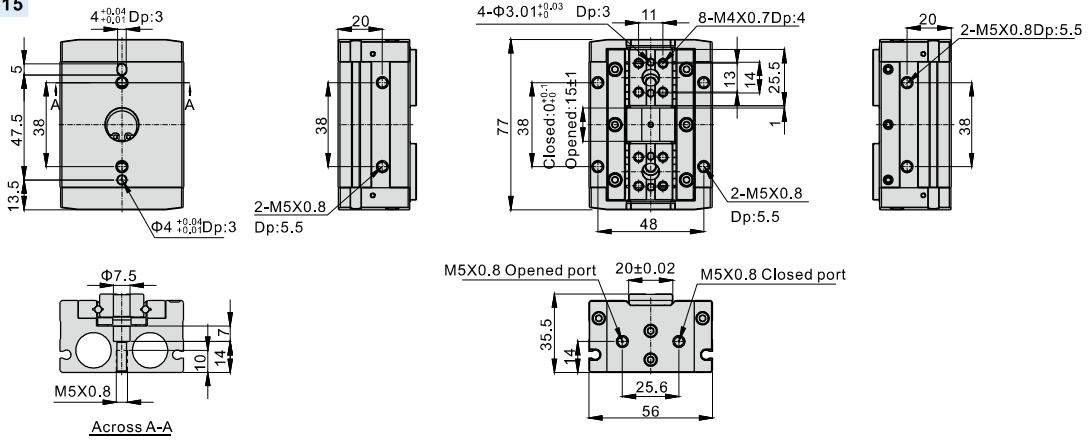

HFD16X30

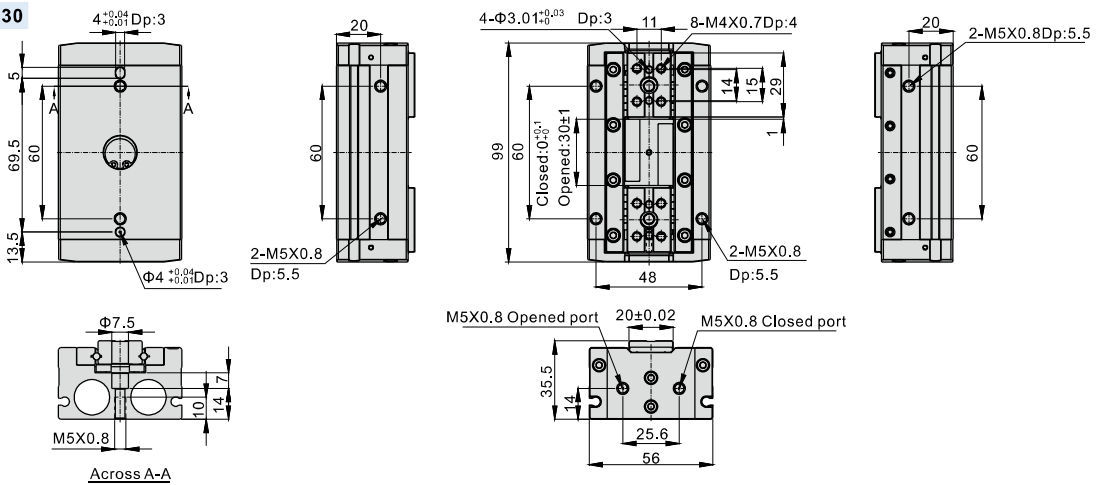

HFD16X60

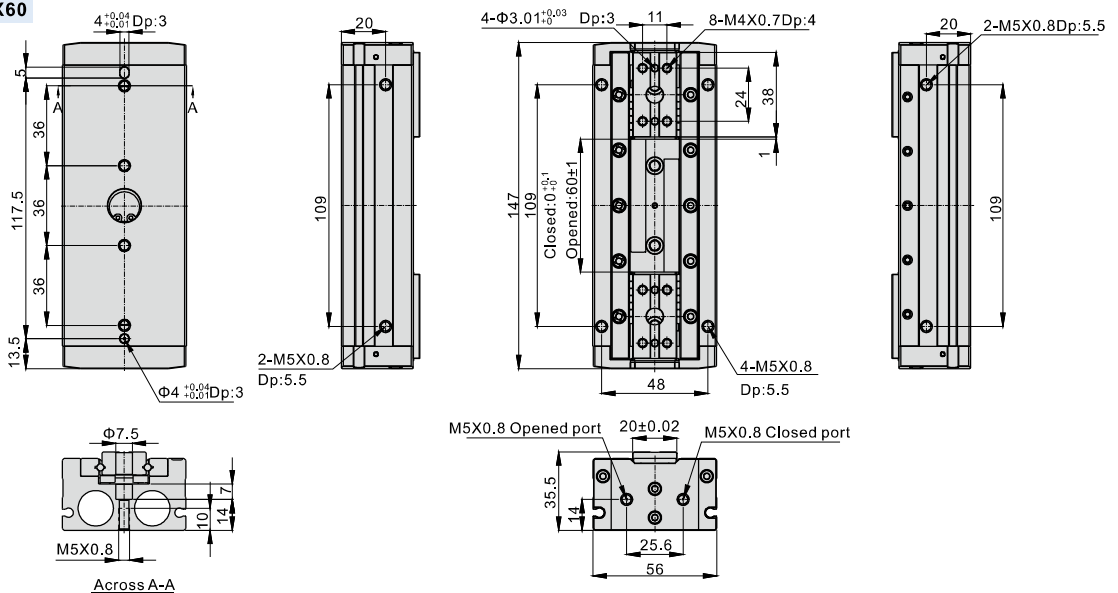

Compact air gripper

HFD Series

HFD20X20

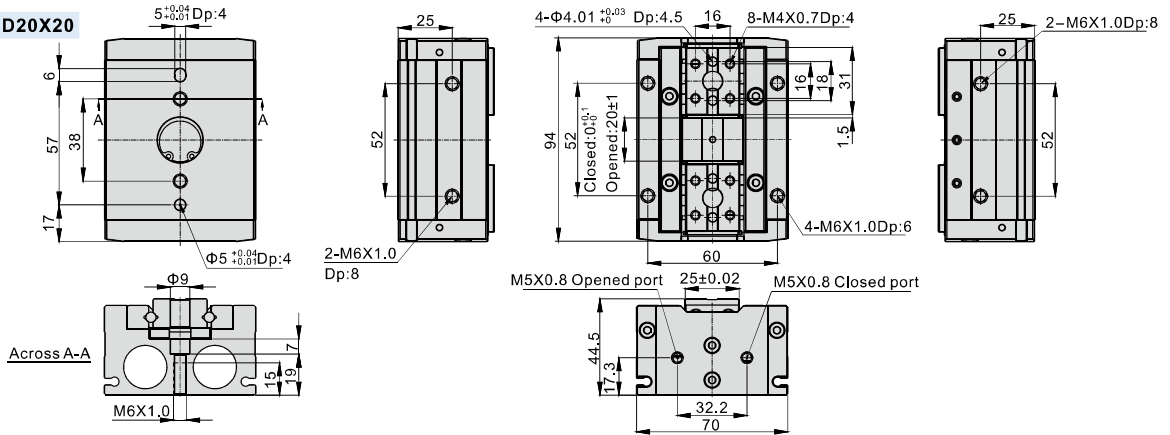

HFD20X40

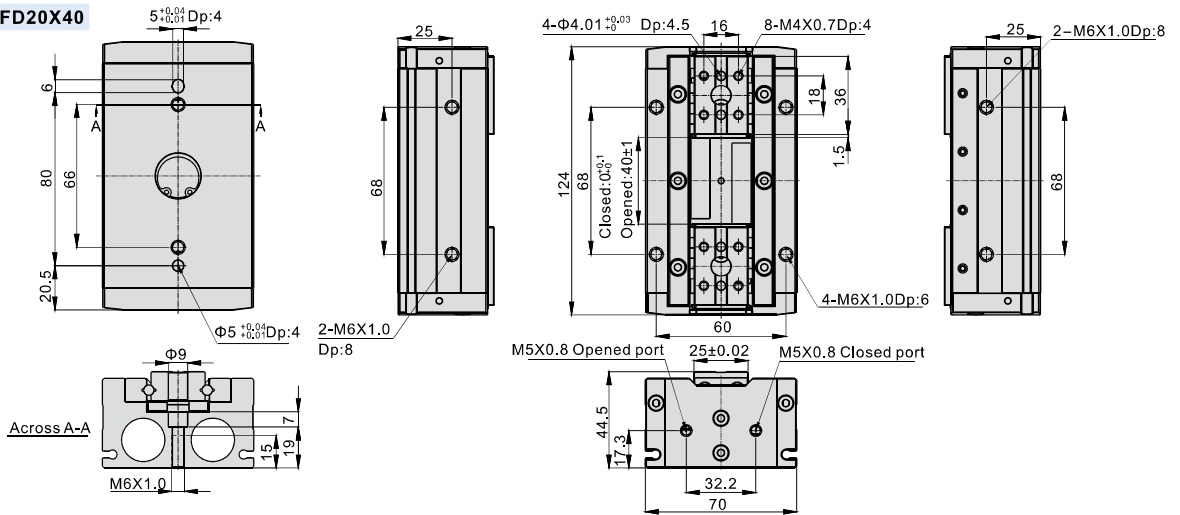

HFD20X80

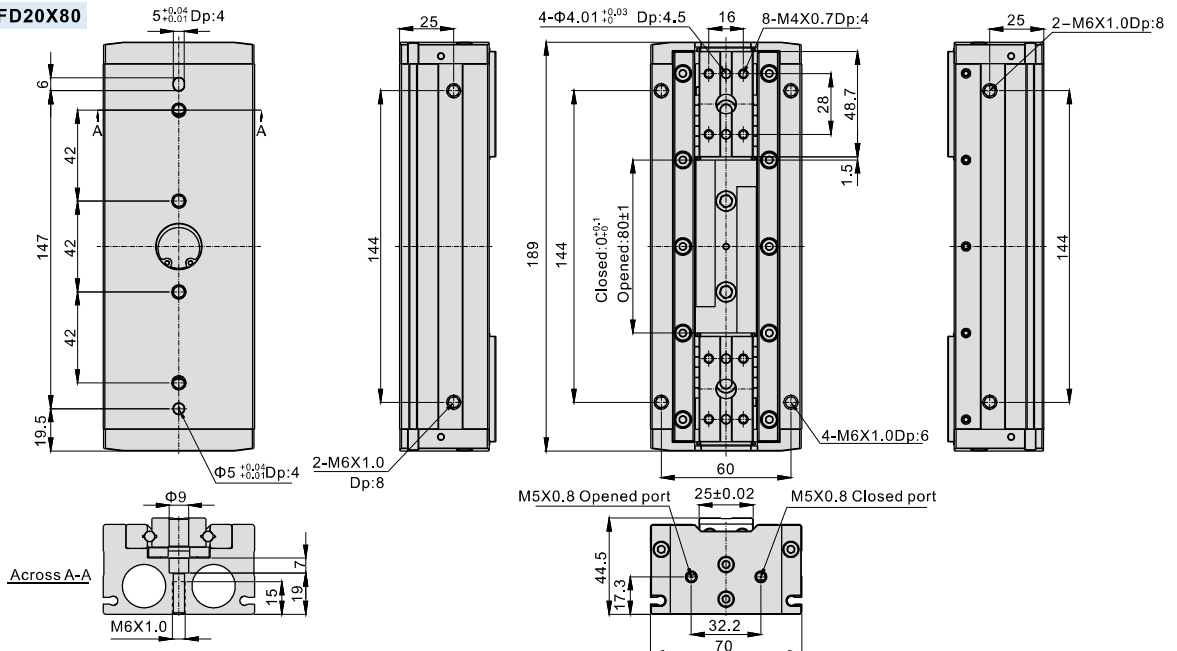

Compact air gripper

HFD Series

HFD25X40

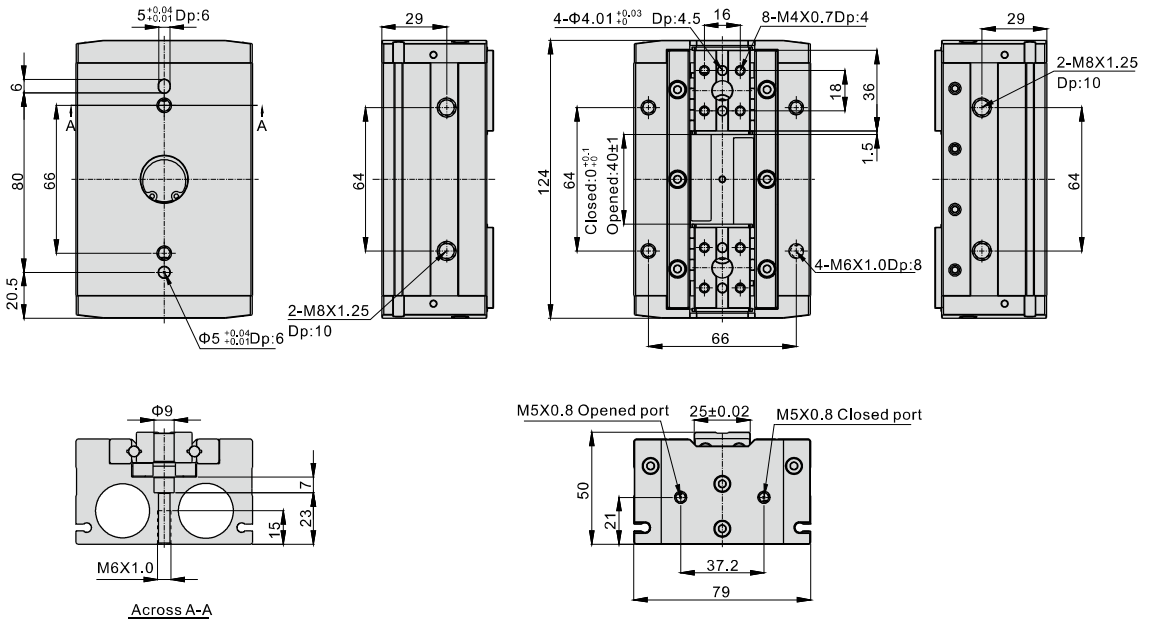

HFD25X80

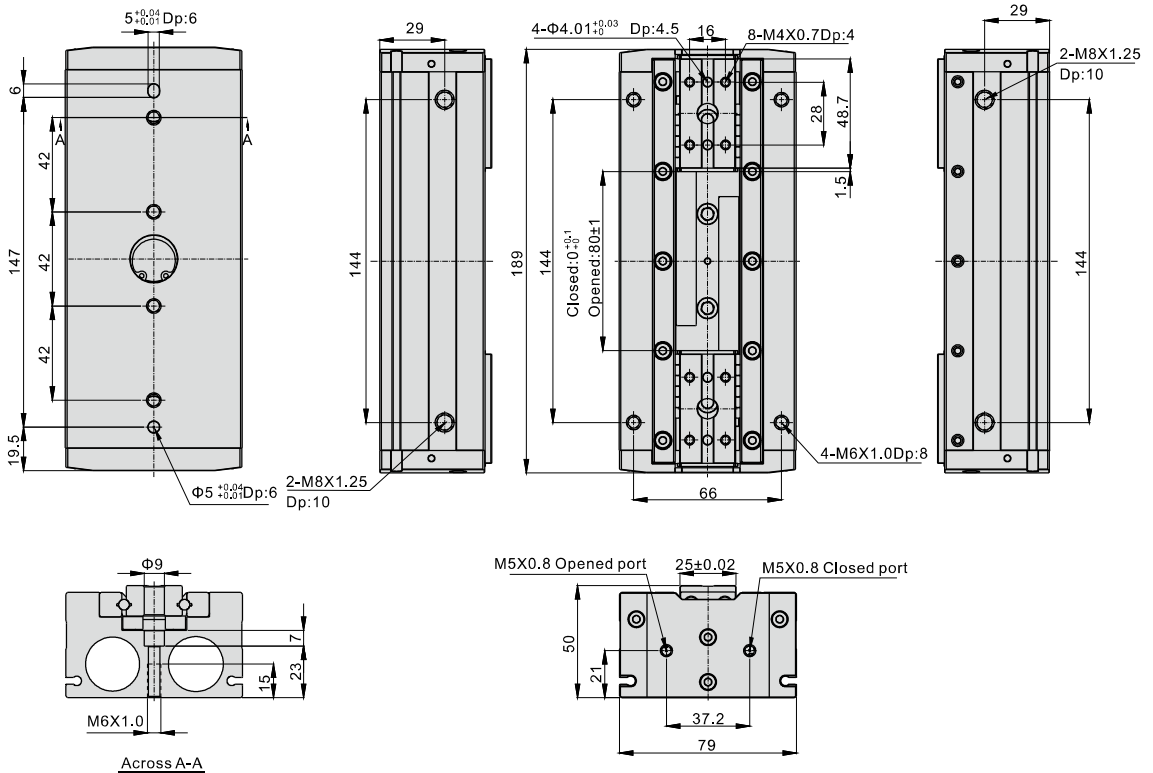

How to select product

Please select pneumatic finger according to the following steps:

① The selection of the effective gripping force



② The confirmation of the gripping point



③ The confirmation of the external force put on the gripping jaw

1. The selection of the gripping force

The gripping work-pieces shown below, on the impact condition of ordinary handling state, taking safety coefficient $a=4$, have a gripping force that is more than 10-20 times of the mass of the gripped objects.

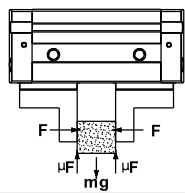

The work-pieces as shown in the left :

n : Number of gripping
 F : Gripping force (N)
 μ : friction coefficient between fittings and work-pieces.
 m : mass of work-pieces
 g : acceleration of gravity ($=9.8m/s^2$)

The condition that the work-pieces won't drop is: $n \times \mu F > mg$

$$\text{so: } F > \frac{mg}{n \times \mu}$$

Safety coefficient is a , so F is:

$$F = \frac{mg}{n \times \mu} \times a$$

$\mu = 0.2$

$$F = \frac{mg}{2 \times 0.2} \times 4 = 10 \times mg$$

10 times of the mass of the gripped objects

$\mu = 0.1$

$$F = \frac{mg}{2 \times 0.1} \times 4 = 20 \times mg$$

20 times of the mass of the gripped objects

Note) If the friction coefficient $\mu > 0.2$, for safety, please also select clamping force according to the principle of 10~20 times of the mass of the clamped objects. As for large acceleration and shock, it requires for greater safety coefficient.

1.1) The actual gripping force must be within the effective gripping forces of different pneumatic fingers specifications shown in the below chart.

Closed gripping force

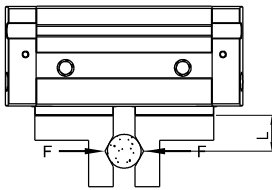

Opened gripping force

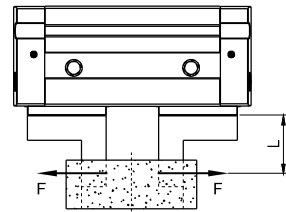

HFD8

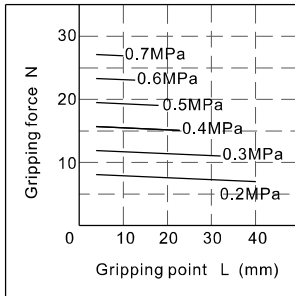

HFD12

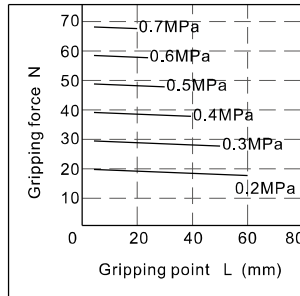

HFD16

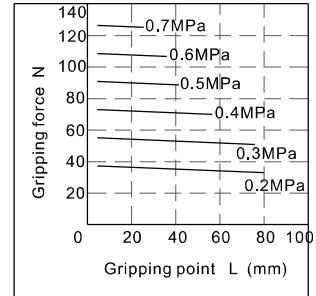

HFD20

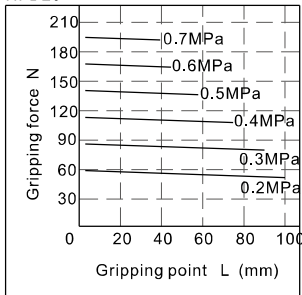

HFD25

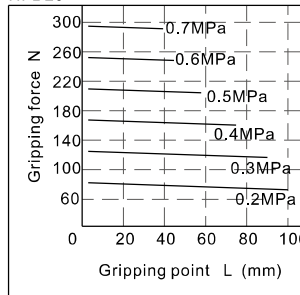

HFD Series

2. The selection of the gripping point

2.1) Please select the gripping point within the limited field shown below.

Over the limits, gripping jaws would be subjected to excessive torque loads, and lead to short life of the air gripper.

L and H have proper sizes

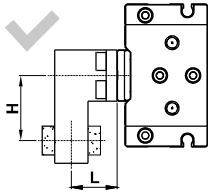

L is too long

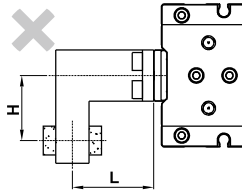

H is too long

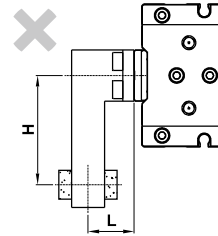

The range of the closed gripping points

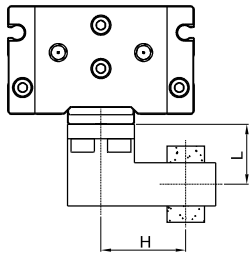

The range of the Opened gripping points

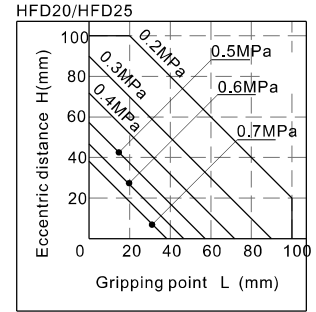
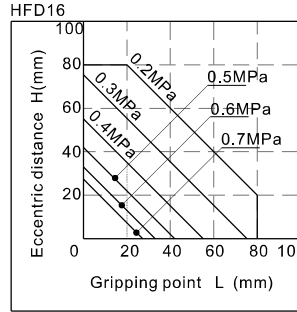
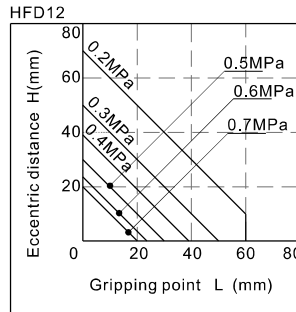
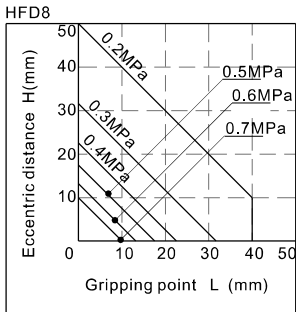
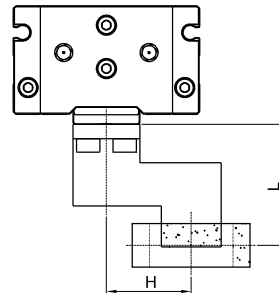

2.2) In the allowable range of gripping point, it is better to design for short and light fittings. If the fittings are long and heavy, the inertia force when the finger is open and close will become larger, and the performance of gripping jaw will be degraded, at the same time it will affect the life.

3. The confirmation of the external force put on the gripping jaw.

Bore size	The allowed vertical loads Fv(N)	Max. permissible torque(Nm)			The calculation of allowable forces when moment loads work	Examples of calculation
		Mp	My	Mr		
8	58	0.26	0.26	0.64	$\text{Allowable load(N)} = \frac{M(\text{Maximum permissible moment})(\text{N.m})}{L \times 10^{-3}}$ Unit conversion constant	In the guide rail of HFD12, the external force of the pitching moment static loads put on the point of L=30mm is f=10 N, $\frac{0.68}{30 \times 10^{-3}} = 22.7(\text{N})$ Actual load f=10(N) < 22.7(N) To meet the using requirements
12	98	0.68	0.68	1.68		
16	176	1.4	1.4	3.36		
20	294	2	2	4.8		
25	294	2	2	4.8		

[Note]
The loads and torque values of said are all static values.
L=Distance to load point(mm).

Installation and application

- Due to the abrupt changes, the circuit pressure is low, which will lead to the decrease of the gripping force and falling of the work-pieces.
In order to avoid the harm to the human body and damage to the equipment, anti-dropping device must be equipped.
- Don't use the air gripper under strong external force and impact force.
- When install and fix the air gripper, avoid falling down, collision and damage.
- When fixing the gripping jaw parts, don't twist the gripping jaw.
- There are several kinds of installation method, and the locking torque of fastening screw must be within the prescribed torque range shown in the below chart.
If the locking torque is too large, it will cause the dysfunctional. If the locking torque is too small, it will cause the position deviation and fall.

Tail installation type

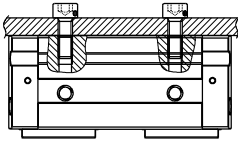

Bore size	The bolts type	Max. locking moment(N.m)	Max. screwed depth(mm)
8	M3×0.5	0.95	6
12	M4×0.7	2.2	8
16	M5×0.8	4.5	10
20	M6×1.0	7.8	15
25	M6×1.0	7.8	15

Side installation type

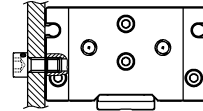

Bore size	The bolts type	Max. locking moment(N.m)	Max. screwed depth(mm)
8	M3×0.5	0.63	4
12	M4×0.7	1.5	5
16	M5×0.8	3	5.5
20	M6×1.0	5.2	8
25	M8×1.25	12	10

Bottom installation type

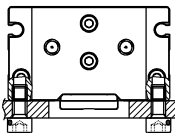

Bore size	The bolts type	Max. locking moment(N.m)	Max. screwed depth(mm)
8	M3×0.5	0.63	4
12	M4×0.7	1.5	5
16	M5×0.8	3	5.5
20	M6×1.0	5.2	6
25	M6×1.0	5.2	8

Front installation type

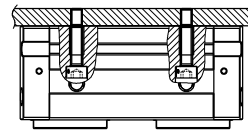

Bore size	The bolts type	Max. locking moment(N.m)
8	M2.5×0.45	0.36
12	M3×0.5	0.63
16	M4×0.7	1.5
20	M5×0.8	5
25	M5×0.8	5

7. The installation method of the gripping jaw fittings

When install the gripping jaw fittings, you have to pay particular attention that you can only hold the gripping jaw by using spanner, and then lock the screws with allen wrench. Never clamp the body directly and then lock the screws, otherwise the parts will be easily damaged.

Bore size	The bolts type	Max. locking moment (N.m)
8	M2.5×0.45	0.36
12	M3×0.5	0.63
16	M4×0.7	1.5
20	M4×0.7	1.5
25	M4×0.7	1.5

