



# Shock absorber—ACA, ACJ Series



## Ordering code

**ACA 20 20 - 1 N**



① Model	② Body male thread	③ Stroke	④ Impact speed	⑤ Prevention crash cap	
ACA: Self-compensation type shock absorber	08:M8	The specification for detail	1: High speed(Light load) 2: Middle speed(Middle load) 3: Low speed(Heavy load)	Blank: Plastic cap N: No cap	
	10:M10			Blank: Plastic cap F: Iron cap N: No cap	
	12:M12				
	14:M14				
	16:M16				
	20:M20				
25:M25					
ACJ: Adjustable type shock absorber	27:M27		Not this code	Blank: Plastic cap F: Iron cap N: No cap	Blank: Plastic cap F: Iron cap
	33:M33				
	36:M36				
	42:M42				

## Product feature

1. Excellent and stable deceleration and shock absorbing; if impacted by load, the resistance will automatically adjust.
2. Outer body of integrated structure is treated by dyed black, which has optimum corrosion and wear resistance and can withstand high pressure; it is easy to install and adjust for all threaded outer body which has good heat dissipation.
3. With high hardness stainless steel shaft, the shock absorber has better impact and corrosion resistance, and it can work under adverse conditions.
4. Special oiling process leads to stable shock absorbing.
5. Compact structure and high max. absorbed energy.
6. We use Special lubricants as buffer medium, which adapts to wide temperature range and ensures stable cushioning.



## ACA, ACJ Series

### Inner structure

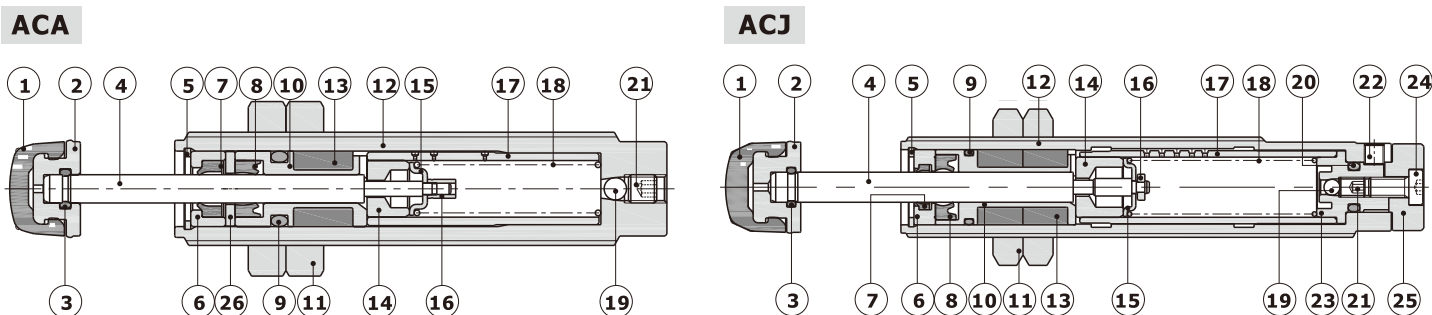

No.	Item	No.	Item	No.	Item	No.	Item	No.	Item	No.	Item
1	Bump cap	6	Front cover	11	Nut	16	Busher	21	Set screw	26	Washer
2	Bump cap(core)	7	Front cover gasket	12	Body	17	Inlet body	22	Set screw		
3	O-ring	8	Front cover gasket	13	Accumulator	18	Spring	23	Back cover		
4	Piston rod	9	O-ring	14	Piston	19	Ball	24	Screw		
5	Clip	10	Correcting body	15	Spring seat	20	O-ring	25	Knob		

### Specification

Model	Stroke (mm)	Max. energy absorbed (N.m)	Max. energy absorbed/hour(Nm/h)	Max. effective mass(kg)			Max. impact speed(m/s)			Weight (g)
				High speed	Middle speed	Low speed	High speed	Middle speed	Low speed	
ACA0806	6	3	5400	5	20	25	4	2	1	12
ACA1007	7	6	14500	10	40	50	4	2	1	26
ACA1210	10	10	30000	18	60	80	4	2	1	40
ACA1215	15	14	35000	25	90	115	4	2	1	48
ACA1412	12	18	36000	30	110	150	4	2	1	70
ACA1416	16	22	39000	40	140	180	4	2	1	78
ACA1420	20	25	45000	45	155	200	4	2	1	85
ACA1616	16	35	43000	60	220	285	4	2	1	105
ACA1620	20	40	47000	70	250	325	4	2	1	115
ACA1625	25	45	51000	80	280	365	4	2	1	125
ACA2020	20	60	50000	240	660	960	4	2	1	175
ACA2025	25	65	54000	260	720	1040	4	2	1	185
ACA2030	30	70	58000	280	780	1120	4	2	1	210
ACA2040	40	80	65000	320	890	1280	4	2	1	225
ACA2525	25	100	75000	400	1100	1600	4	2	1	290
ACA2550	50	150	85000	600	1650	2400	4	2	1	370
ACA2725	25	140	85000	560	1550	2240	4	2	1	372
ACA2750	50	250	95000	1000	2780	4000	4	2	1	475
ACA3325	25	180	100000	720	2000	2880	4	2	1	596
ACA3350	50	300	120000	1200	3300	4800	4	2	1	750
ACA3625	25	220	135000	880	2400	3500	4	2	1	702
ACA3650	50	350	150000	1400	2500	5600	4	2	1	889

Model	Stroke (mm)	Max. energy absorbed (N.m)	Max. energy absorbed/hour(Nm/h)	Max. effective mass(kg)	Max. impact speed(m/s)	Weight (g)
ACJ1007	7	6	14500	50	4	28
ACJ1210	10	10	30000	80	4	43
ACJ1412	12	20	36000	160	4	75
ACJ2020	20	60	50000	960	4	189
ACJ2525	25	100	75000	1600	4	308
ACJ2550	50	150	85000	2400	4	395
ACJ2725	25	140	85000	2240	4	396
ACJ2750	50	250	95000	4000	4	510
ACJ3325	25	180	100000	2880	4	540
ACJ3350	50	300	110000	4800	4	800
ACJ3625	25	220	125000	2500	4	750
ACJ3650	50	350	130000	5600	4	950
ACJ4225	25	350	150000	5600	4	1150
ACJ4250	50	700	180000	11200	4	1420
ACJ4275	75	1050	210000	16800	4	1720



## ACA, ACJ Series

### Max. absorbed energy and speed curve

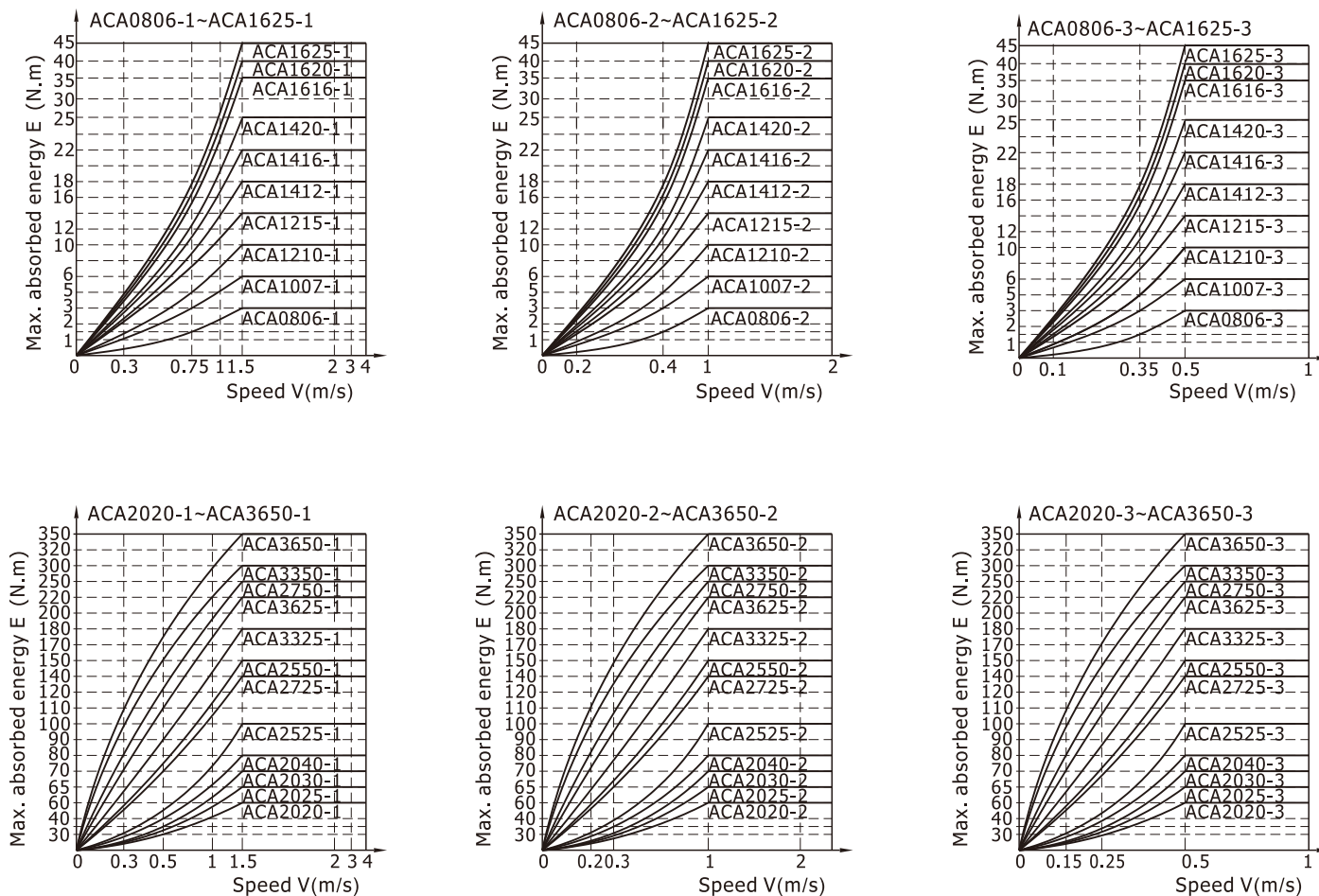

Note: 1. The interval under the red line shows the energy range absorbed by corresponding shock absorber.  
 2. It is better to use 20%-80% of the Max. absorbed energy.

### Buffer curve

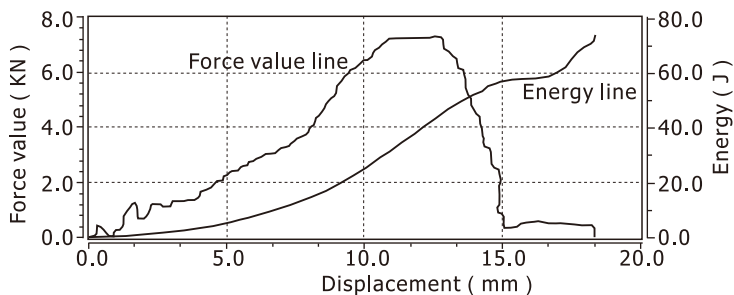

Note: As the chart shows, energy is absorbed by a lower reaction force at the beginning of the stroke, then by a smooth linear deceleration. It decelerates smoothly at last.

## ACA, ACJ Series

### Dimensions

#### ACA

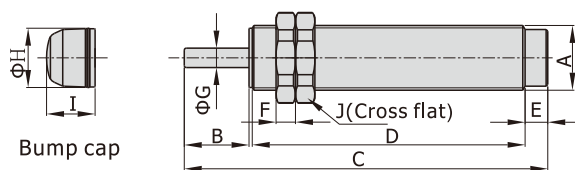

[Unit: mm]

Model\Item	A	B	C	D	E	F	G	H	I	J
ACA0806	M8×1.0	6	46	32	5	4	3	6.5	6	11
ACA1007	M10×1.0	7	56	41	5	4	3	8.5	7.5	14
ACA1210	M12×1.0	10	63.5	47.5	5	4	3	10	7.5	17
ACA1215	M12×1.0	15	79	58	5	4	3	10	7.5	17
ACA1412	M14×1.5	12	80.5	62.5	5	6	4	12	12	19
ACA1416	M14×1.5	16	92.5	70.5	5	6	4	12	12	19
ACA1420	M14×1.5	20	103	77	5	6	4	12	12	19
ACA1616	M16×1.5	16	100.5	78.5	5	6	5	14	12	21
ACA1620	M16×1.5	20	109	83	5	6	5	14	12	21
ACA1625	M16×1.5	25	125	94	5	6	5	14	12	21
ACA2020	M20×1.5	20	112.5	84.5	7	6	6	18	15	26
ACA2025	M20×1.5	25	122.5	89.5	7	6	6	18	15	26
ACA2030	M20×1.5	30	142	104	7	6	6	18	15	26
ACA2040	M20×1.5	40	167.5	119.5	7	6	6	18	15	26
ACA2525	M25×1.5	25	123	89	8	6	6	23	16	32
ACA2550	M25×1.5	50	183	124	8	6	6	23	16	32
ACA2725	M27×1.5	25	127	93	8	6	8	24.5	17	36
ACA2750	M27×1.5	50	192	133	8	6	8	24.5	17	36

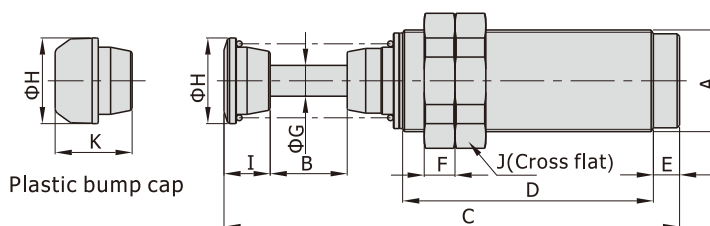

[Unit: mm]

Model\Item	A	B	C	D	E	F	G	H	I	J	K
ACA3325	M33×1.5	25	148	81.5	8.5	10	10	27.8	15	41	25
ACA3350	M33×1.5	50	213	121.5	8.5	10	10	27.8	15	41	25
ACA3625	M36×1.5	25	148	81.5	8.5	10	10	27.8	15	46	25
ACA3650	M36×1.5	50	213	121.5	8.5	10	10	27.8	15	46	25

# Accessories—Shock absorber

## ACA, ACJ Series

### ACJ

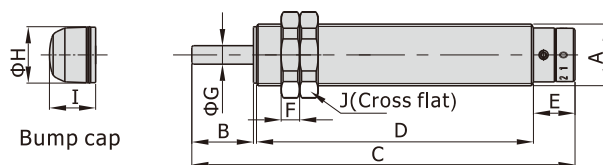

Bump cap

[Unit: mm]

Model\Item	A	B	C	D	E	F	G	H	I	J
ACJ1007	M10×1.0	7	67	45.5	11	4	3	8.5	7.5	14
ACJ1210	M12×1.0	10	74	52	11	4	3	10	7.5	17
ACJ1412	M14×1.5	12	91	66.5	11.5	6	4	12	12	19
ACJ2020	M20×1.5	20	124.5	90	13.5	6	6	18	15	26
ACJ2525	M25×1.5	25	132.5	92	14.5	6	6	23	16	32
ACJ2550	M25×1.5	50	192.5	127	14.5	6	6	23	16	32
ACJ2725	M27×1.5	25	137	96.5	14.5	6	8	24.5	17	36
ACJ2750	M27×1.5	50	202	136.5	14.5	6	8	24.5	17	36

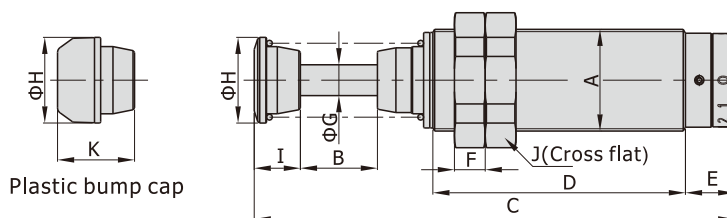

Plastic bump cap

[Unit: mm]

Model\Item	A	B	C	D	E	F	G	H	I	J	K
ACJ3325	M33×1.5	25	156	82	16	10	10	27.8	15	41	25
ACJ3350	M33×1.5	50	221	122	16	10	10	27.8	15	41	25
ACJ3625	M36×1.5	25	156	82	16	10	10	27.8	15	46	25
ACJ3650	M36×1.5	50	221	122	16	10	10	27.8	15	46	25
ACJ4225	M42×1.5	25	161.5	85.5	16	12	12	34.8	15	50	25
ACJ4250	M42×1.5	50	226.5	125.5	16	12	12	34.8	15	50	25
ACJ4275	M42×1.5	75	291.5	165.5	16	12	12	34.8	15	50	25

# Accessories—Shock absorber

## ACA, ACJ Series

### Accessories

#### How to set stop collar

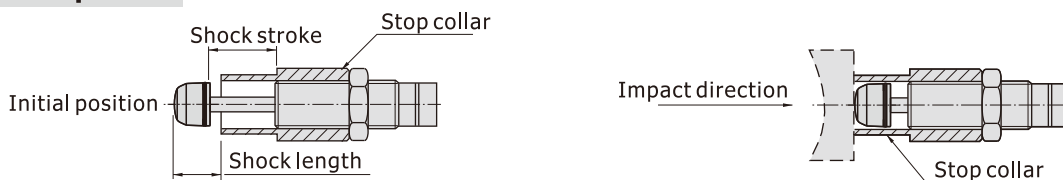

#### Ordering code

### F - ACA 08 LM

- ① ② ③ ④

① Accessory	② Model	③ Female thread size	④ Accessories type
		08:M8	LM: Stop collar
		10:M10	
		12:M12	
		14:M14	
		16:M16	
		20:M20	
		25:M25	
		27:M27	
		33:M33	
		36:M36	LM: Stop collar \ FA: Flange
		42:M42	FA: Flange

#### Dimensions

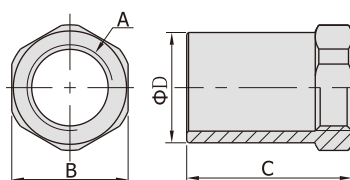
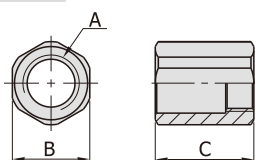

Model\Item	A	B	C	D
F-ACA14LM	M14×1.5	19	27	18
F-ACA16LM	M16×1.5	21	32	20
F-ACA20LM	M20×1.5	26	35	25
F-ACA25LM	M25×1.5	32	45	31
F-ACA27LM	M27×1.5	36	50	35
F-ACA33LM	M33×1.5	41	80	40
F-ACA36LM	M36×1.5	46	80	45

Model\Item	A	B	C
F-ACA08LM	M8×1.0	11	14
F-ACA10LM	M10×1.0	14	16
F-ACA12LM	M12×1.0	17	20

#### Selecting list

##### F-ACA36FA

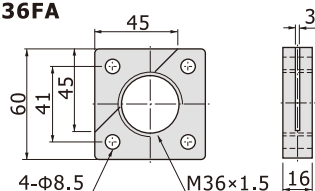

##### F-ACA42FA

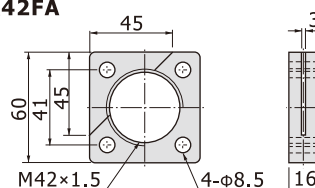

Model	Compatible absorber
F-ACA08LM	ACA0806
F-ACA10LM	ACA1007, ACJ1007
F-ACA12LM	ACA1210, ACA1215, ACJ1210
F-ACA14LM	ACA1412, ACA1416, ACA1420, ACJ1412
F-ACA16LM	ACA1616, ACA1620, ACA1625
F-ACA20LM	ACA2020, ACA2025, ACA2030, ACA2040, ACJ2020
F-ACA25LM	ACA2525, ACA2550, ACJ2525, ACJ2550
F-ACA27LM	ACA2725, ACA2750, ACJ2725, ACJ2750
F-ACA33LM	ACA3325, ACA3350, ACJ3325, ACJ3350
F-ACA36LM	ACA3625, ACA3650, ACJ3625, ACJ3650
F-ACA36FA	ACA3625, ACA3650, ACJ3625, ACJ3650
F-ACA42FA	ACJ4225, ACJ4250, ACJ4275

## ACA, ACJ Series

### How to select



Theoretical energy parameter table for cylinders under no-load state

Unit:J(N.m)

Stroke(mm)	6	7	10	12	15	16	20	25	30	40	50	75	
Bore size (mm)	6	0.102	0.119	0.170	0.203	0.254	0.271	0.339	0.424	0.509	0.678	0.848	1.27
	8	0.181	0.211	0.301	0.362	0.452	0.482	0.603	0.754	0.904	1.21	1.51	2.26
	10	0.283	0.330	0.471	0.565	0.707	0.754	0.942	1.18	1.413	1.88	2.36	3.53
	12	0.407	0.475	0.678	0.814	1.017	1.085	1.36	1.70	2.035	2.71	3.39	5.09
	16	0.723	0.844	1.21	1.45	1.809	1.929	2.41	3.01	3.617	4.82	6.03	9.04
	20	1.13	1.32	1.88	2.26	2.826	3.014	3.77	4.71	5.652	7.54	9.42	14.13
	25	1.77	2.06	2.94	3.53	4.416	4.710	5.89	7.36	8.831	11.8	14.7	22.1
	32	2.89	3.38	4.82	5.79	7.235	7.717	9.65	12.1	14.47	19.3	24.1	36.2
	40	4.52	5.28	7.54	9.04	11.3	12.06	15.1	18.8	22.6	30.1	37.7	56.5
	50	7.07	8.24	11.8	14.1	17.7	18.84	23.6	29.4	35.33	47.1	58.9	88.3
	63	11.2	13.1	18.7	22.4	28.0	29.91	37.4	46.7	56.08	74.8	93.5	140.2
	80	18.1	21.1	30.1	36.2	45.2	48.23	60.3	75.4	90.43	120.6	150.7	226.1
	100	28.3	33.0	47.1	56.5	70.7	75.36	94.2	117.8	141.3	188.4	235.5	353.3
	125	44.2	51.5	73.6	88.3	110.4	117.8	147.2	184.0	220.8	204.4	368.0	552.0
	160	72.3	84.4	120.6	144.7	180.9	192.9	241.2	301.4	361.7	482.3	602.9	904.3
	200	113.0	131.9	188.4	226.1	282.6	301.4	376.8	471.0	565.2	753.6	942.0	1413.0
250	176.6	206.1	294.4	353.3	441.6	471.0	588.5	735.9	883.1	1177.5	1471.9	2207.8	
320	289.4	337.6	482.3	578.8	723.5	771.7	964.6	1205.8	1446.9	1929.2	2411.5	3617.3	

#### For example:

When the pressure is 0.6MPa, bore size of  $\phi 40$  under no-load state plus shock stroke of 12mm can produce energy of 9.04 N.m.

Refer to the specification table, you will find ACA1412 fits.

Note: Cylinders under full-load state can produce as twice as the energy shown above.

## Installation and Operation

- The scale range of adjustable shock absorbers is 0 to 9 (8). Factory set is at 6 (4) position. 0 means the softest, while 9 means the hardest;
- Correct selection of shock absorbers can ensure a smooth deceleration and good shock absorbing properties;
- If there exists rebounding at the beginning of the stroke, it shows the effective weight is too high. In this case, self-compensation type shall be replaced by high speed type (-1), while adjustable type shall be adjusted to softer, that is closer to 0;
- If there exists rebounding at the end of the stroke, it shows the effective weight is too low. In this case, self-compensation type shall be replaced by low speed type (-3), while adjustable type shall be adjusted to harder, that is closer to 9;
- In the work process, lateral load should be avoided as possible as one can. Eccentric angle must be controlled within  $3^\circ$ . Shock absorbers shall be securely locked;
- The operating temperature range shall be  $-5$  to  $70^\circ\text{C}$ ;
- To extend the service life, piston shall be stopped 1mm before reaching the end. It is better to install set screw with positioning and precise adjustment;
- If two or more shock absorbers are installed at the same side, please make sure that they act synchronously;
- No painting, welding or cleaning with corrosive substance on the body as well as the piston rod.
- When installed the absorber, the moment forced on absorber can't be out of the range given in below list or may cause the absorber damage.

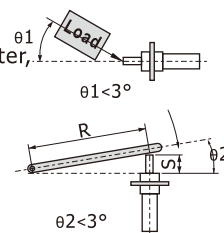

Compatible absorber	Male thread Spec(of body)	Max. Assembly Force on Absorber(N.m)
ACA0806	M8×1.0[Note]	2.0
ACA1007、ACJ1007	M10×1.0	3.5
ACA1210、ACA1215、ACJ1210	M12×1.0	8.0
ACA1412、ACA1416、ACA1420、ACJ1412	M14×1.5	11.0
ACA1616、ACA1620、ACA1625	M16×1.5	15.0
ACA2020、ACA2025、ACA2030、ACA2040、ACJ2020	M20×1.5	24.0
ACA2525、ACA2550、ACJ2525、ACJ2550	M25×1.5	40.0
ACA2725、ACA2750、ACJ2725、ACJ2750	M27×1.5	63.0

[Note] When ACA0806 is selected, bottom diameter of internal thread before tapping is  $\Phi 7.1^{+0.1}_0$ .



## ACA, ACJ Series

### Calculation of energy under load state

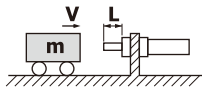
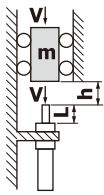
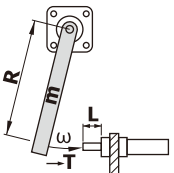
Horizontal impact	Vertical impact	Rotation impact
1) Horizontal impact   Impact weight (kg): m Impact speed (m/s): v Kinetic energy (J(N.m): $E1 = \frac{m \times v^2}{2}$ Propelling energy(J(N.m): E2=0 Gross energy (J(N.m): E=E1+E2	1) Free fall   Impact weight (kg): m Impact speed (m/s): v Kinetic energy (J(N.m): $E1 = m \times g \times h$ Propelling energy(J(N.m): $E2 = m \times g \times L$ Gross energy (J(N.m): E=E1+E2	1) Rocker   Impact weight (kg): m Impact speed (m/s): $v = R \times \omega$ Kinetic energy (J(N.m): $E1 = \frac{I \times \omega^2}{2}$ Propelling energy(J(N.m): $E2 = \frac{T \times L}{R}$ Gross energy (J(N.m): E=E1+E2

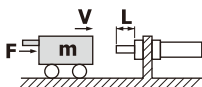
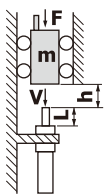
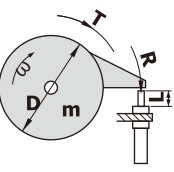
2) Horizontal impact with cylinder thrust   Impact weight (kg): m Impact speed (m/s): v Kinetic energy (J(N.m): $E1 = \frac{m \times v^2}{2}$ Propelling energy(J(N.m): E2=F×L Gross energy (J(N.m): E=E1+E2	2) Push-down by cylinder   Impact weight (kg): m Impact speed (m/s): v Kinetic energy (J(N.m): $E1 = \frac{m \times v^2}{2}$ Propelling energy(J(N.m): $E2 = (mg + F) \times L$ Gross energy (J(N.m): E=E1+E2	2) Rotation   Impact weight (kg): m Impact speed (m/s): $v = R \times \omega$ Kinetic energy (J(N.m): $E1 = \frac{I \times \omega^2}{2}$ Propelling energy(J(N.m): $E2 = \frac{T \times L}{R}$ Gross energy (J(N.m): E=E1+E2
--	--	--

Code	Explanation	Unit	Code	Explanation	Unit	Code	Explanation	Unit
m	Impact weight	kg	F	Thrust( $(\pi \times D^2 \times P) / 4$ )	N	N	Round per Minute	rpm
v	Impact speed	m/s	D	Nore size	mm	R	Distance fron rotation center to impact point	m
E	Gross energy	J(N.m)	P	Air pressure	MPa			
E1	Kinetic energy(Potential energy)	J(N.m)	L	Shock stroke	m	I	Moment of Inertia ( $I = mr^2 / 2$ )	kg×m <sup>2</sup>
E2	Propelling energy	J(N.m)	h	Height	m	ω	Angular velocity( $\omega = 2\pi N / 60$ ) (90°=1.57rad/s)	rad/s
g	Gravity acceleration	9.8(m/s <sup>2</sup> )	T	Torque	N.m			