

Push-pull valve(5/2way)

4L Series



Ordering code

4L 2 10 08 T



① Model	② Code	③ Valve type	④ Port size	⑤ Thread type
4L: 5 port 2 position push-pull valve	1: 100 Series	10: 2 position	06: 1/8"	T: NPT
	2: 200 Series		06: 1/8" 08: 1/4"	
	3: 300 Series		08: 1/4" 10: 3/8"	

Specification

Model	4L110-06	4L210-06	4L210-08	4L310-08	4L310-10
Fluid	Air (to be filtered by 40 μm filter element)				
Operating	Manual control direct acting type				
Port size[Note1]	1/8"		1/4"		3/8"
Orifice size [Note3]	10.2mm ² (Cv=0.6)	4L210-08:17.0mm ² (Cv=1.0)		4L310-10:28.0mm ² (Cv=1.65)	
Valve type	5/2 Way				
Lubrication [Note2]	Not required				
Pressure range	0~145psi(0~1.0MPa)				
Proof pressure	215psi(1.5MPa)				
Temperature	-20~70°C				
Material of body	Aluminum alloy				

[Note1] NPT thread is available.

[Note2] Once lubricated air is used, continue with same medium to optimise valve life span.

It is suggested to use ISO VG32 lubricant or the oil with the same grade.

[Note3] Equivalent orifice S and Cv are all calculated from the flow rate data.

Push-pull valve(5/2way)

4L Series

Inner structure

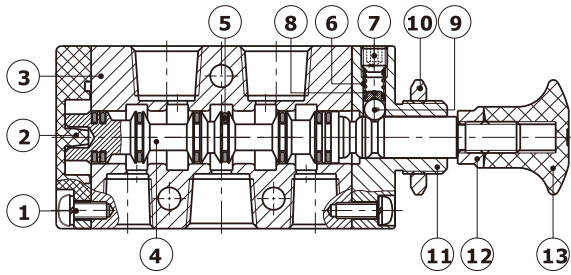

No.	Item	No.	Item	No.	Item
1	Round head screw	6	Spring	11	Top cover
2	Bottom cover	7	Stop screw	12	Safety nut
3	Body	8	Spring holder	13	Hand grip
4	Spool	9	Steel ball		
5	O-ring	10	Hexagon nut		

Flow chart

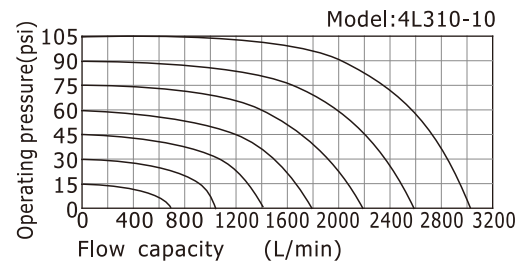
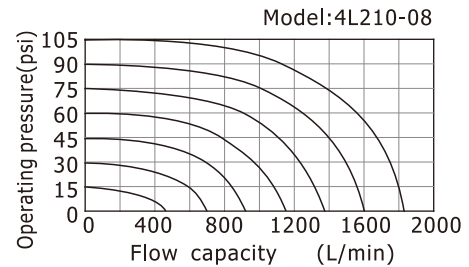
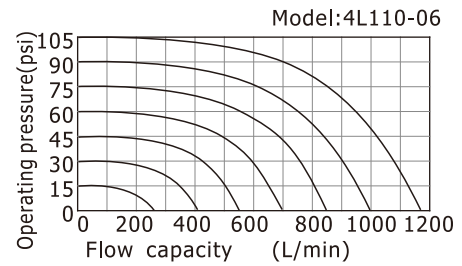

The data in flow rate chart are obtained from AirTAC lab.

Dimensions

[Unit: mm]

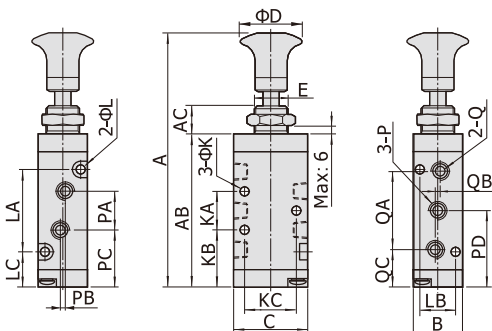

Item\Model	4L11006	4L21006	4L21008	4L31008	4L31010
A	98	106	106	121.5	121.5
AB	58.8	65.8	65.8	81	81
AC	10	10	10	10	10
B	18	22	22	27	27
C	27	35	35	40	40
D	25	25	25	25	25
E	M12×0.75	M14×1.0	M14×1.0	M16×1.0	M16×1.0
K	3.3	4.3	4.3	4.3	4.3
KA	14	20	20	24	24
KB	22	22.5	22.5	28.5	28.5
KC	19	23.5	23.5	27.5	27.5
L	3.3	3.3	3.3	4.3	4.3
LA	30	38	38	50	50
LB	13	17	17	20	20
LC	14	13.5	13.5	15.5	15.5
P	1/8"	1/8"	1/4"	1/4"	3/8"
PA	16	18	21	22	24
PB	3	0	3	0	4
PC	21	23.5	22	29.5	28.5
PD	29	32.5	32.5	40.5	40.5
Q	1/8"	1/8"	1/8"	1/4"	1/4"
QA	28	36	36	45	45
QB	2	0	0	0	0
QC	15	14.5	14.5	18	18

Push-pull valve(3/2way)

3L Series



Ordering code

3L 2 10 08 T



① Model	② Code	③ Valve type	④ Port size	⑤ Thread type
3L: 3 port 2 position push-pull valve	1: 100 Series	10: 2 position	06: 1/8"	T: NPT
	2: 200 Series		06: 1/8" 08: 1/4"	
	3: 300 Series		08: 1/4" 10: 3/8"	

Specification

Model	3L110-06	3L210-06	3L210-08	3L310-08	3L310-10
Fluid	Air (to be filtered by 40 μm filter element)				
Operating	Manual control direct acting type				
Port size[Note1]	1/8"		1/4"		3/8"
Orifice size [Note3]	10.2mm ² (Cv=0.6)	3L210-08:17.0mm ² (Cv=1.0)		3L310-10:28.0mm ² (Cv=1.65)	
Valve type	3/2 Way				
Lubrication [Note2]	Not required				
Pressure range	0~145psi(0~1.0MPa)				
Proof pressure	215psi(1.5MPa)				
Temperature	-20~70°C				
Material of body	Aluminum alloy				

[Note1] NPT thread is available.

[Note2] Once lubricated air is used, continue with same medium to optimise valve life span.

It is suggested to use ISO VG32 lubricant or the oil with the same grade.

[Note3] Equivalent orifice S and Cv are all calculated from the flow rate data.

Push-pull valve(3/2way)

3L Series

Inner structure

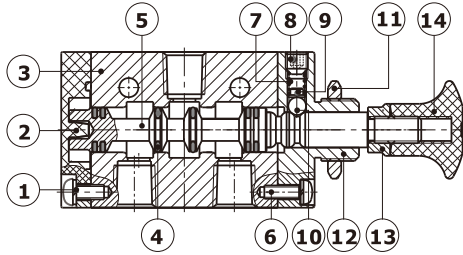

No.	Item	No.	Item	No.	Item
1	Round head screw	6	Round head screw	11	Hexagon nut
2	Bottom cover	7	Spring	12	Top cover
3	Body	8	Stop screw	13	Safety nut
4	O-ring	9	Spring holder	14	Hand grip
5	Spool	10	Steel ball		

Flow chart

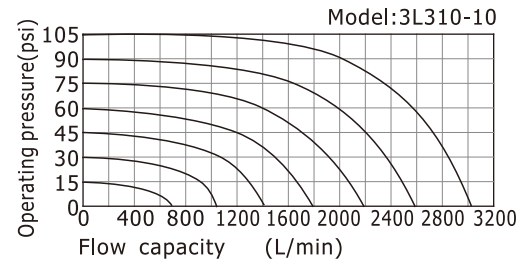
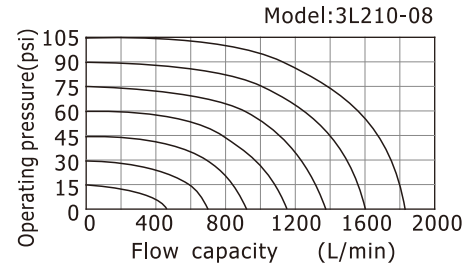
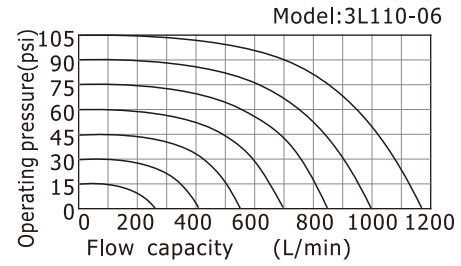

The data in flow rate chart are obtained from AirTAC lab.

Dimensions

[Unit: mm]

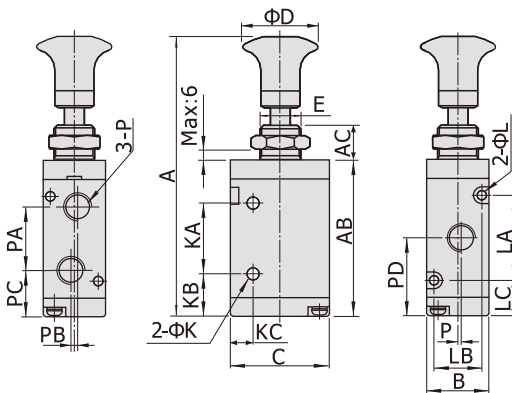

Item\Model	3L11006	3L21006	3L21008	3L31008	3L31010
A	87	98	98	106.5	106.5
AB	47.8	57.8	57.8	66.5	66.5
AC	10	10	10	10	10
B	18	22	22	27	27
C	27	35	35	40	40
D	25	25	25	25	25
E	M12×0.75	M14×1.0	M14×1.0	M16×1.0	M16×1.0
K	3.1	4.3	4.3	4.3	4.3
KA	21	25	25	30	30
KB	13	16	16	18	18
KC	7.7	8	8	10	10
L	3.3	3.3	3.3	4.3	4.3
LA	19	30	30	35	35
LB	13	17	17	20	20
LC	14	13.5	13.5	15.5	15.5
P	1/8"	1/8"	1/4"	1/4"	3/8"
PA	16	22.5	22.5	24	24
PB	2	0	0	0	0
PC	15.5	17.5	17.5	21	21
PD	24.5	28.5	28.5	33	33
PE	1	0	1.5	0	2