

Fluid control valve(2/2 way)



2KLA Series (Direct-acting and normally opened)



Ordering code

Ordering code of valves

2KLA H 030 08 A □ T

① ② ③ ④ ⑤ ⑥ ⑦

① Model	2KLA: 2/2 way direct-acting and normally opened	
② Pressure condition	H: High pressure Blank: Standard	
③ Size series	030: 030 Series	050: 050 Series
④ Port size	06: 1/8" 08: 1/4"	10: 3/8" 15: 1/2"
⑤ Voltage	A: AC220V B: DC24V C: AC110V E: AC24V F: DC12V	
⑥ Electrical entry	Blank: Terminal I: Grommet[Note]	
⑦ Thread type	T: NPT	

[Note] The wire length is 0.5m.

Ordering code of accessories

Ordering code of accessories is the same as 2WA series valve's, Please refer to P19 for details of ordering code.

Specification

Model\Item	Port size [Note1]	Orifice size (Φmm)	Cv	Valid area or section (mm ²)	Weight [Note2](g)	Max.operating pressure differentia		Proof pressure	
						MPa	psi	MPa	psi
2KLAH030	-06 1/8"	2.0	0.18	3.0	243.5	1.5	220	3.0	450
	-08 1/4"				233.5				
2KLA030	-06 1/8"	3.0	0.33	6.0	243.5	0.7	100	3.0	450
	-08 1/4"				233.5				
2KLAH050	-10 3/8"	4.0	0.55	10.0	528	1.5	220	3.0	450
	-15 1/2"				508				
2KLA050	-10 3/8"	5.0	0.83	15.0	528	0.7	100	3.0	450
	-15 1/2"				508				

[Note1] NPT thread is available.

[Note2] The weight in the table is the terminal valve's weight, 2KLA030 series grommet valve's weight is 10g less than terminal's. 2KLA050 series grommet valve's weight is 20g less than terminal's.

Fluid control valve(2/2 way)



2KLA Series (Direct-acting and normally opened)

Product feature

1. Direct acting and normally opened type 2/2 way solenoid valve. Its high sensibility allows it to change direction quickly;
2. It has wide pressure range, including standard high pressure (H) to choose from;
3. It is compact, small size and light weight. It is easy to install and dismantle.
4. The valve body is made of SUS304 . Its coil has a Heat resistance classification of Class H. The standard seal material is PTFE(Teflon) which is suitable for a variety of working medium such as water with high temperature and vapour.
5. The protection class of the coil is IP65 and there is a choice for grommet or terminal electrical entry .

Flow chart

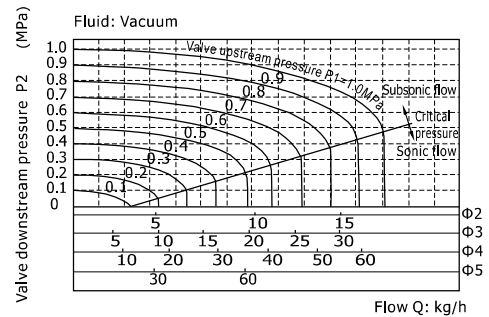

Valve's specification

Acting		Direct acting			
Initial state		Normally opened			
Adaptable fluid		Steam, High temperature Water, Oil			
Viscosity limit		Under 20CST			
Ambient and fluid temperature (°C)	Max.	Oil 150	Water 150	Steam 183	Ambient 100
	Min.	-10 [Note1]	1	-	-20

[Note1] 50CST or less.

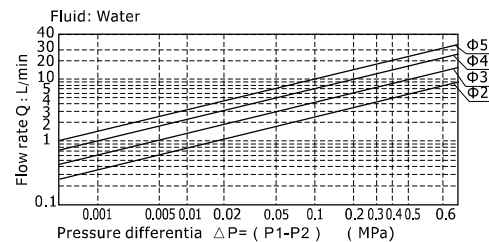

Inner structure

2KLA030 (Terminal)

No.	Item	No.	Item	No.	Item
1	Body	6	Fixed plate	11	Connector
2	Airtight ring	7	Gasket washer	12	Airtight bush
3	Spring	8	Mandril	13	Electromagnet
4	Steel bushing	9	Coil assembly	14	Screw
5	O-ring	10	Coil nut	15	Spring

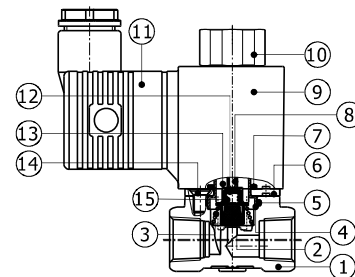

Specification of coil

Valve type	Coil type	Power type	Frequency (Hz)	Voltage range	Electrical entry	Power Consumption (VA/W)	Insulation	Temp. rise(°C)		
2KLA□030	CDA110KH CLA110KH	AC	50	±15%	Terminal (CDA)	10.0VA	Class H	50		
			60			8.0VA		45		
		DC	-	±10%		7.0W		50		
2KLA□050	CDA160KH CLA160KH	AC	50	±15%		Grommet (CLA)		25.0VA	Class H	65
			60					±10%		22.0VA
		DC	-	±10%				10.5W		50



Fluid control valve(2/2 way)



2KLA Series (Direct-acting and normally opened)

Dimensions

2KLA□030(Terminal)

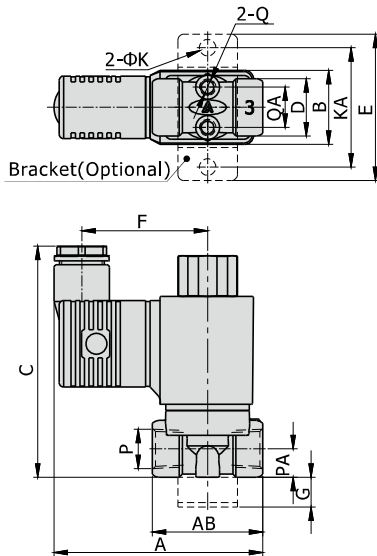

2KLA□030(Grommet)

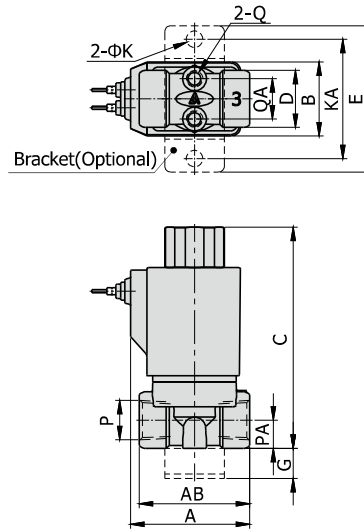

2KLA□050(Terminal)

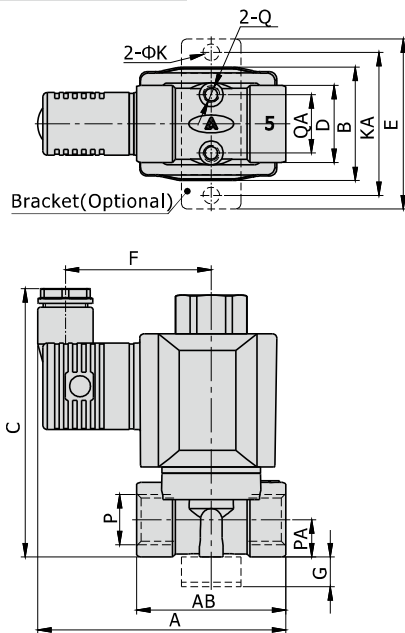

2KLA□050(Grommet)

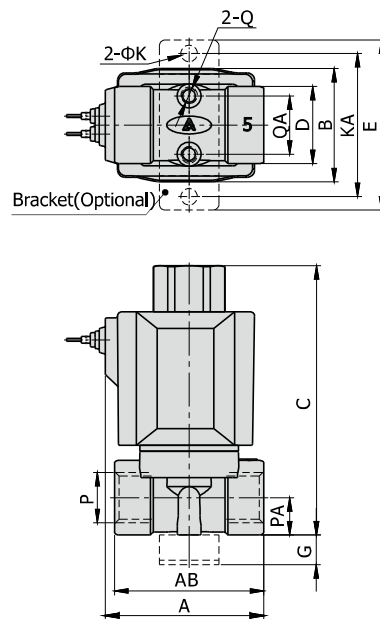

[Unit:mm]

[Unit:mm]

Model\Item	A	AB	B	C	D	E	F	G	K	KA	P	PA	Q	QA
2KLA□030-06	70	37	25	77.5	19	49	42	10	5.5	40	1/8"	9.5	M5	13.5
2KLA□030-08	70	37	25	77.5	19	49	42	10	5.5	40	1/4"	9.5	M5	13.5
2KLA□050-10	83	50	38	90	26	57	49	10	5.5	48	3/8"	12.5	M5	19.5
2KLA□050-15	83	50	38	90	26	57	49	10	5.5	48	1/2"	12.5	M5	19.5

Model\Item	A	AB	B	C	D	E	G	K	KA	P	PA	Q	QA
2KLA□030-06	40	37	25	74	19	49	10	5.5	40	1/8"	9.5	M5	13.5
2KLA□030-08	40	37	25	74	19	49	10	5.5	40	1/4"	9.5	M5	13.5
2KLA□050-10	53	50	38	90	26	57	10	5.5	48	3/8"	12.5	M5	19.5
2KLA□050-15	53	50	38	90	26	57	10	5.5	48	1/2"	12.5	M5	19.5



Fluid control valve(2/2 way)



2KLA Series (Internally piloted and normally opened)

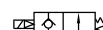

Ordering code

Ordering code of valves **2KLA 150 15 A □ T**

1
2
3
4
5
6

① Model	2KLA: 2/2 way internally piloted and normally opened					
② Orifice size	150: Φ15mm	200: Φ20mm	250: Φ25mm	320: Φ35mm	400: Φ40mm	500: Φ50mm
③ Port size	15: 1/2"	20: 3/4"	25: 1"	32: 1 1/4"	40: 1 1/2"	50: 2"
④ Voltage	A: AC220V B: DC24V C: AC110V E: AC24V F: DC12V					
⑤ Electrical entry	Blank: Terminal I: Grommet[Note]					
⑥ Thread type	T: NPT					

[Note] The wire length is 0.5m.

Ordering code of accessories

Ordering code of accessories is the same as 2WA series valve's, Please refer to P21 for details of ordering code.

[Note] 320\400\500 series valves do not have mounting accessories.

Specification

Model\Item	Port size [Note1]	Orifice size (Φmm)	Cv	Valid area or section (mm ²)	Weight [Note2](g)	Operating pressure differentia		Proof pressure	
						MPa	psi	MPa	psi
2KLA150-15	1/2"	15.0	5.50	100.0	569	Max: 0.7 Min: 0.05	Max: 100 Min: 10	1.5	220
2KLA200-20	3/4"	20.0	9.50	170.0	722				
2KLA250-25	1"	25.0	12.50	220.0	1026				
2KLA320-32	1 1/4"	35.0	23.00	420.0	2261				
2KLA400-40	1 1/2"	40.0	31.00	560.0	2641				
2KLA500-50	2"	50.0	49.00	880.0	3508				

[Note1] NPT thread is available.

[Note2] The weight in the table is the terminal valve's weight, 2KLA150~250 series grommet valve's weight is 10g less than terminal's. 2KLA320~500series grommet valve's weight is 20g less than terminal's.



Fluid control valve(2/2 way)



2KLA Series (Internally piloted and normally opened)

Product feature

1. Indirect acting (Internal pilot) and normally opened type 2/2 way solenoid valve. Its high sensibility allows it to change direction quickly.
2. It is compact, small size and light weight. It is easy to install and dismantle.
3. The valve body is made of SUS304. Its coil has a Heat resistance classification of Class H. The standard seal material is PTFE (Teflon) which is suitable for a variety of working medium such as water with high temperature and vapour.
4. The protection class of the coil is IP65 and there is a choice for grommet or terminal electrical entry.

Flow chart

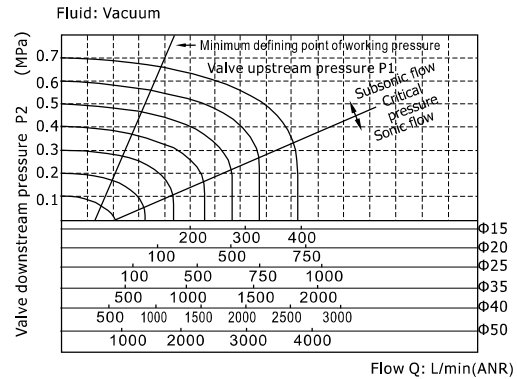

Valve's specification

Acting		Internally piloted			
Initial state		Normally opened			
Adaptable fluid		Steam, High temperature Water, Oil			
Viscosity limit		Under 20CST			
Ambient and fluid temperature (°C)		Oil	Water	Steam	Ambient
	Max.	150	150	183	100
	Min.	-10 [Note1]	1	-	-20

[Note1] 50CST or less.

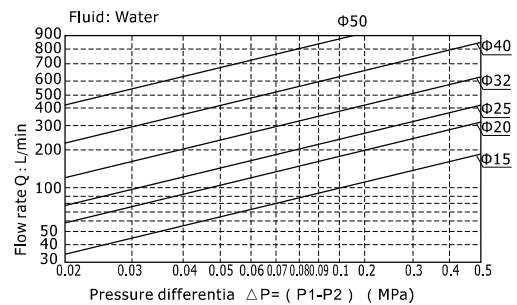

Inner structure

2KLA150 (Grommet)

No.	Item	No.	Item
1	Body	12	Steel bushing
2	Position	13	O-ring
3	Wear ring	14	Airtight ring
4	Gasket	15	Fixed plate
5	Cover	16	Gasket washer
6	Screw	17	Mandril
7	Spring	18	Coil assembly
8	Spring	19	Coil nut
9	Plug	20	Spring
10	Spring	21	Airtight bush
11	Screw		

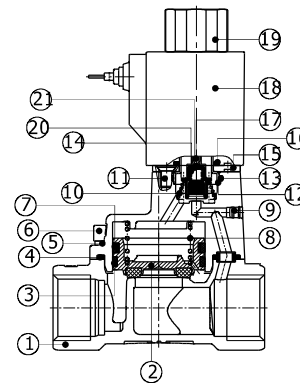

Specification of coil

Valve type	Coil type	Power type	Frequency (Hz)	Voltage range	Electrical entry	Power Consumption (VA/W)	Insulation	Temp. rise (°C)
2KLA150	CDA110KH CLA110KH	AC	50	±15%	Terminal (CDA)	10.0VA	Class H	50
2KLA200			60			8.0VA		45
2KLA250		DC	-	±10%		6.5W		50
2KLA320	CDA160K-H CLA160K-H	AC	50	±15%	Grommet (CLA)	25.0VA	Class H	65
2KLA400			60			22.0VA		60
2KLA500		DC	-	±10%		12.0W		50



Fluid control valve(2/2 way)



2KLA Series (Internally piloted and normally opened)

Dimensions

2KLA150~250(Terminal)

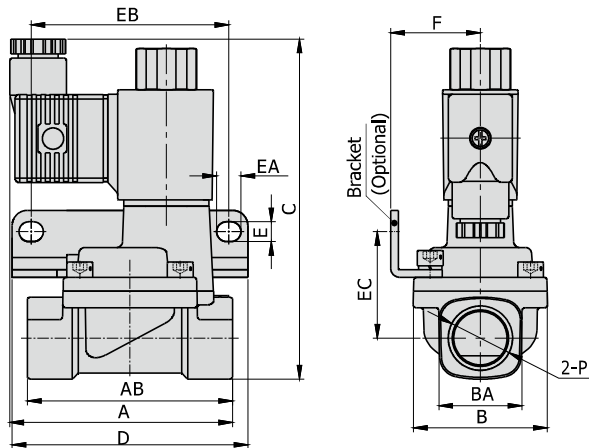

2KLA150~250(Grommet)

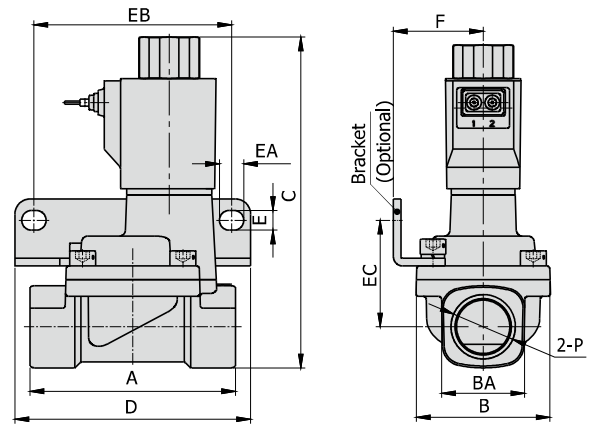

2KLA320~500(Terminal)

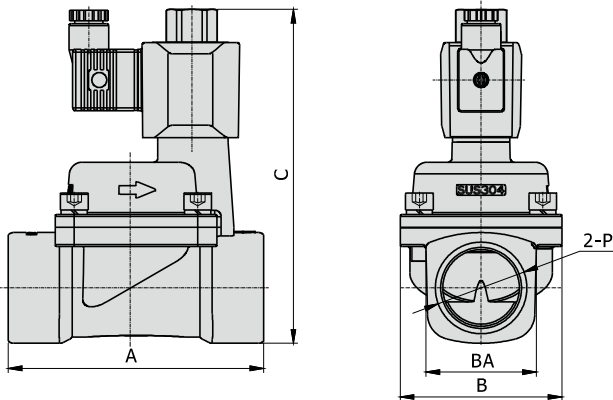

2KLA320~500(Grommet)

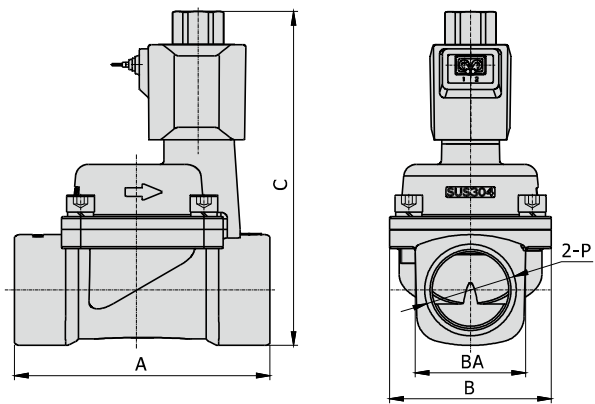

[Unit:mm]

Model\Item	A	AB	B	BA	C	D	E	EA	EB	EC	F	P
2KLA150-15	73.5	67.5	44	27.5	112	77.5	6.5	8	65	35	29.5	1/2"
2KLA200-20	75.5	79.5	51	33.5	119	87.5	6.5	8	75	38	33	3/4"
2KLA250-25	77.5	90	57	40.5	126	93	6.5	8	80	42	35	1"
2KLA320-32	120	-	76	52	165.5	-	-	-	-	-	-	1 1/4"
2KLA400-40	126	-	86	58	175.5	-	-	-	-	-	-	1 1/2"
2KLA500-50	144	-	96	70	186.5	-	-	-	-	-	-	2"

[Unit:mm]

Model\Item	A	B	BA	C	D	E	EA	EB	EC	F	P
2KLA150-15	67.5	44	27.5	1M2	77.5	6.5	8	65	35	29.5	1/2"
2KLA200-20	79.5	51	33.5	109	87.5	6.5	8	75	38	33	3/4"
2KLA250-25	90	57	40.5	116	93	6.5	8	80	42	35	1"
2KLA320-32	120	76	52	156.5	-	-	-	-	-	-	1 1/4"
2KLA400-40	126	86	58	164.5	-	-	-	-	-	-	1 1/2"
2KLA500-50	144	96	70	179.5	-	-	-	-	-	-	2"



Fluid control valve



Coil and accessories



Ordering code of coil

CD A110 □ A □

① ② ③ ④ ⑤

① Coil type	② Coil's bore	③ Valve type	④ Voltage	⑤ Temperature resistance class
CD: Terminal CL: Grommet	A110: Coil Specification (Bore sizeΦ10.0mm) A160: Coil Specification (Bore sizeΦ16.0mm)	Blank: For Normally Closed valve type For Normally Opened valve type	A: AC220V B: DC24V C: AC110V E: AC24V F: DC12V	Blank: F Class H: H Class

Specification

Model\Item	Power type	Voltage (V)	Frequency (Hz)	Voltage range	Electrical entry	Power Consumption (VA/W)		Insulation	Temp.rise (°C)
						For NC	For NO		
110 Series	AC	220	50	± 15%	DIN Terminal	10.0VA	15.0VA	Class F	50
			60			8.0VA	11.0VA		45
		110	50			10.0VA	15.0VA		50
			60			8.0VA	11.0VA		45
		24	50			10.0VA	15.0VA		50
			60			8.0VA	11.0VA		45
	DC	24	-	± 10%	Grommet	6.5W			50
		12							
160 Series	AC	220	50	± 15%	DIN Terminal	25.0VA	35.0VA	Class F	65
			60			22.0VA	30.0VA		60
		110	50			25.0VA	35.0VA		65
			60			22.0VA	30.0VA		60
		24	50			25.0VA	35.0VA		65
			60			22.0VA	30.0VA		60
	DC	24	-	± 10%	Grommet	12.0W			50
		12							

Fluid control valve



Coil and accessories

Hookup

Coil's type		Hookup
110 Series	CDA110 (Terminal)	AC
		DC
	CLA110 (Grommet)	AC
160 Series	CDA160 (Terminal)	AC
		DC
	CLA160 (Grommet)	AC
		DC

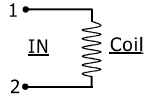

How to use connector

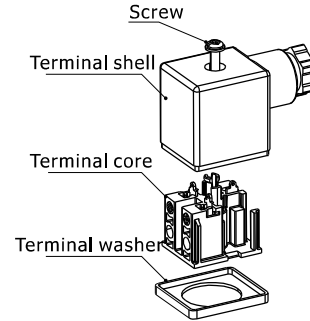

How to select coil

Valve type\Coil type	110Series		160 Series	
	Class F	Class H	Class F	Class H
2SA□030 2KSA□030	●	×	×	×
2SA□050 2KSA□050	×	×	●	×
2SA150~250 2KSA150~250	●	×	×	×
2SA320~500 2KSA320~500	×	×	●	×
2WA□030 2KWA□030	●	×	×	×
2WA□050 2KWA□050	×	×	●	×
2WA150~250 2KWA150~250	●	×	×	×
2LA□030 2KLA□030	×	●	×	×
2LA□050 2KLA□050	×	×	×	●
2LA150~250 2KLA150~250	×	●	×	×
2LA320~500 2KLA320~500	×	×	×	●

How to select accessories

Valve type\Accessories type	F-2WA030LB	F-2WA050LB	F-2WA150LB	F-2WA200LB	F-2WA250LB
2SA□030 2KSA□030	●	×	×	×	×
2SA□050 2KSA□050	×	●	×	×	×
2SA150 2KSA150	×	×	●	×	×
2SA200 2KSA200	×	×	×	●	×
2SA250 2KSA250	×	×	×	×	●
2WA□030 2KWA□030	●	×	×	×	×
2WA□050 2KWA□050	×	●	×	×	×
2WA150 2KWA150	×	×	●	×	×
2WA200 2KWA200	×	×	×	●	×
2WA250 2KWA250	×	×	×	×	●
2LA□030 2KLA□030	●	×	×	×	×
2LA□050 2KLA□050	×	●	×	×	×
2LA150 2KLA150	×	×	●	×	×
2LA200 2KLA200	×	×	×	●	×
2LA250 2KLA250	×	×	×	×	●